

**Studies on Multiple Access Schemes for  
High Performance  
Wireless Local Area Networks**

**高能率無線ローカルエリアネットワーク  
における多元アクセス方式に関する研究**

July 2012

DINH Chi Hieu

# **Studies on Multiple Access Schemes for High Performance Wireless Local Area Networks**

**高能率無線ローカルエリアネットワーク  
における多元アクセス方式に関する研究**

July 2012

Graduate School of Global Information and Telecommunication Studies  
Waseda University

Wireless Communication and Satellite Communication Research Project II

DINH Chi Hieu

# Summary

In this dissertation, we focus on the new MAC protocol design for high speed data transmission for wireless local area networks. The proposals, mathematical analysis and numerical simulations are demonstrated in chapter 3, 4, and 5. The dissertation presents two new MAC protocols and a mathematical analysis solution of One-ACK protocol. This document summarizes the achievements of this dissertation, discusses some open issues and future development as followings:

1. Chapter 1 provides overview of the current and near future wireless network. This chapter also points out the serious challenging to the wireless transmission protocol. It is foreseen that wireless communication will have to deliver huge amount of data to meet the increasing need of end users. To meet this requirement, new spectrum should be allocated and innovative technologies should be applied. The process of allocating new spectrum is quite slow and may never meet the spectrum requirement of mobile community. Therefore short term solutions may come from new technologies such as: better coding, MIMO, off-loading techniques, etc. The off-loading approach is the most viable technology. Most of the heavy traffic such as huge file downloading, video streaming, etc. should go through high speed wired networks and then only deliver to end user by wireless technologies such as femtocell or WLAN. The simple, highly effective and world-wide deployed WLAN networks is the most suitable solution. Exploring such capability is the active research trend currently. Besides identifying the research topic, this chapter also introduces plan and structure of this dissertation.
2. Chapter 2 reviews relevant MAC protocols to the research. MAC protocol study is an old research topic which we can trace back to the very beginning of communication system. However, it is among the most active research areas. Most

of the new communication systems come with new MAC protocol. It is therefore impossible to have a comprehensive review of this area. In this dissertation, we only focus on the related schemes, which directly or indirectly influence the final outcome of our effort to design a more suitable MAC protocol of high performance wireless networks. Those many wireless MAC schemes have origin from ALOHA protocol, the development of wireless technology recently yield a very diverse wireless MAC scheme family. We, therefore, try to follow the development of each branch to highlight the idea development, performance improvement and major academic achievements. During the course of studying the above mentioned protocols, we paid special attention to the analytic parts. The analytic solution plays a key role in any protocol research as it is an important tool to investigate the behavior of system as a whole. One of the powerful tools for MAC protocol performance analysis is Markov chain framework. Markov chain analysis has been successfully applied to investigate several MAC scheme. Our achievements based firmly on these analytic solutions.

3. Chapter 3 introduces the Continuous Contention-Assisted Transmission (CAT) MAC protocol for wireless ad-hoc network. The proposal used the idea of token in wired-network to apply to wireless environment. Although originated from wired-network scheme, the proposal differs from token protocol in several aspects. Firstly, not every wireless station can receive token. Secondly, the error prone wireless environment may destroy the token unexpectedly. And finally, wireless network is a highly dynamic network, stations can join and leave the network without prior notification. This characteristic should be included in the wireless version of token scheme. At first, a set of stations in close proximity should form into a group to coordinate transmissions. Ideally all station in group should be within transmission range in order to the token is handled reliably. The right to transmit frame of a station on shared wireless channel is

decided by previously successful receiving stations. Giving the right to access channel to station has data in the queue will much reduce its random access effort. If the token is passed to station with no demand for channel access then this token is killed. A new phase of random access begins. Transmissions are organized distributedly to reduce conflict among group. In low traffic network, the CAT protocol behaves as random access protocol. When traffic increase, transmissions of stations are quickly scheduled to eliminate unnecessary collisions. Direct result of this proposal is the increase of group throughput. The proposal is suitable for small networks which stations are closed enough to be efficiently organize into non-contending group. The proposed protocol is analysed from mathematical analysis and simulation standpoint. Using Markov chain analysis, the theoretical solution proved the superiority of this proposal. Numerical simulation confirmed the feasibility of CAT protocol in various scenarios. The study in this chapter has only confined in the one group communication. To advance this research trend, several aspects of this protocol need to be studied further, such as: hidden terminal issue, interaction of several groups.

4. Chapter 4 presented the mathematical analysis of one-ACK protocol. One ACK protocol is a very promising candidate for high speed MAC protocol of WLANs. With the demand of large data transmission in high speed network, the major requirement to deliver such huge data is put into the MAC protocol design. Naturally, high speed communication requires big transmission packets. However large frames cannot reliably transmit through wireless channel. Any small error will corrupt the whole frame reception and consequently causes a costly retransmission. The error in wireless channel is busy in nature. Strong error correction code is not enough to counter the adverse effect of bad wireless channel. Therefore it is best to fragment the big packet into smaller ones with optimum size. When error happens during the transmission, the MAC layer can

localizes the corrupted parts in the original frame. The MAC layer then decides to retransmit the only fragments that have been corrupted by channel. The idea reduces much of unnecessary retransmission of large frames. Furthermore, one-ACK organizes retransmission of corrupted fragments so as to reduce overhead. The protocol had only been investigated by simulation by NS-2 previously. It is needed a concrete mathematical proof to complete the proposal. In this chapter, we presented an analytic solution with erroneous wireless channels are included. Retransmission policy is also incorporated into the solution in order to assist the designers. The solution can precisely predict the performance of one-ACK protocol under various simulations setting of retransmission strategies. Several error models can be introduced to the solution to bring it into a wider application.

5. Chapter 5 described a new MAC protocol design for very high speed transmission wireless network called iLAC. iLAC took a very different approach with conventional MAC protocol designs. Normally, the transmission process is matter to transmitter and receiver alone. This chapter investigate the scenario that many stations involve in the transmission. Even the overhearing stations can actively participate in the scheduling process to avoid future conflict. The scheduling job is mainly decided by a coordinator node. However in highly dynamic wireless network, installing another management layer is quite costly solution. The coordinator solution will become less efficient in partially connected wireless network. Therefore it is needed distributed coordination scheme to handle the coordination work. We proposed iLAC protocol to address this problem. Neighboring stations are jointly decide transmission time by exchanging information. Transmitting station notifies its next backoff stage setting in the header frames. Overhearing stations know status of the ongoing transmitting station. They adjust their backoff value accordingly to avoid future conflict

with that station. Therefore collisions are eliminated efficiently as neighboring stations dynamically schedule transmissions. Coordinating transmission by this scheme reduce wasteful energy significantly due to unproductive colliding transmissions. Mathematical analysis using Markov chain shows excellent agreement with simulations. Using real power consumption measurement data, we show significant improvement in the power consumption structure of stations. In real wireless environment, not all stations can overhear correctly the transmitting frames. The lack of global knowledge of network yields certain level of conflict in transmission. This research topic is currently under investigation.

6. Chapter 6 provides our conclusions on the achievements of this study. We currently investigate other aspect of the proposed MAC protocol. Some of the promising topics are outlined as near future researches.

# Acknowledgements

This dissertation completes my achievements of research activities at Graduate School of Global Information and Telecommunication Studies, Waseda University, Japan, under the supervision of Prof. Shigeru Shimamoto. I would like to express my gratitude to Prof. Shigeru Shimamoto for his guidance and support throughout my PhD life. I would also like to thank to members of Shimamoto's Laboratory for their continuous support.

I would like to extend sincerely thanks to Prof. Yoshio Yamada of Faculty of Science and Engineering, Waseda University. Attending Prof. Yamada's class prepared me a firm foundation to advance in my specific field of study. I would also like to extend sincerely thanks to Prof. Ken Sawada, school of commerce, Waseda University for encouragement and great support in my study of Markov chain model. Countless discussions with Prof. Yamada and Prof. Sawada helped me finish the analytic work of my research.

Finally, I would like to show my respect for my parents, who always show unconditional love and support to my study.

This work was supported by the Monbukagakusho Scholarship.

**Dinh Chi Hieu**

Mar. 2012



To my loving wife and parents who have supported me throughout my PhD life.

In loving memory of grandparent.

# Contents

Summary . . . . .	iii
Acknowledgements . . . . .	viii
List of Tables . . . . .	xiii
List of Figures . . . . .	xiv
<b>1 Introduction</b>	<b>1</b>
1.1 The global traffic demand . . . . .	1
1.2 Possible solutions for mobile traffic growth . . . . .	4
1.3 The role of Medium Access Control (MAC) . . . . .	6
1.4 Thesis Layout . . . . .	7
<b>2 Multiple Access Techniques</b>	<b>9</b>
2.1 Introduction to multiple access techniques . . . . .	9
2.2 Frequency Division Multiple Access (FDMA) . . . . .	10
2.3 Time Division Multiple Access (TDMA) . . . . .	11
2.4 Code Division Multiple Access (CDMA) . . . . .	12
2.5 ALOHA Systems and Protocols . . . . .	14
2.5.1 Unslotted ALOHA . . . . .	15
2.5.2 Slotted ALOHA . . . . .	17
2.6 Carrier Sense Systems and Protocols . . . . .	21
2.6.1 Nonpersistent CSMA . . . . .	22

2.6.2	1-persistent CSMA . . . . .	23
2.6.3	$p$ -persistent CSMA . . . . .	26
2.7	Tree Algorithm . . . . .	29
2.7.1	Statistic binary tree . . . . .	30
2.7.2	Optimum dynamic tree protocol . . . . .	31
2.8	WLAN protocol . . . . .	33
2.8.1	IEEE 802.11 General Architecture . . . . .	33
2.8.2	Distributed coordination function . . . . .	35
2.9	FAWAC protocol . . . . .	40
2.9.1	Performance of FAWAC under different conditions . . . . .	42
2.10	ALOHA with capture effect . . . . .	43
2.11	Sequentially assigned power level based multiple access scheme . . . . .	45
2.12	Conclusion . . . . .	48
<b>3</b>	<b>Continuous Contention-Assisted Transmission MAC Protocol</b>	<b>53</b>
3.1	Introduction . . . . .	54
3.2	Continuous Assisted Transmission Protocol . . . . .	54
3.3	Analytical model . . . . .	57
3.3.1	Basic equations . . . . .	59
3.3.2	Normalized condition . . . . .	62
3.3.3	Key transition probabilities . . . . .	63
3.4	Model validations and Simulation result . . . . .	64
3.4.1	Fairness Issue . . . . .	66
3.5	Conclusion . . . . .	68
<b>4</b>	<b>One-ACK Protocol</b>	<b>72</b>
4.1	Introduction . . . . .	72
4.2	One-ACK protocol . . . . .	73

4.3	Analytical model for One-ACK protocol . . . . .	77
4.4	Simulation verification . . . . .	82
4.5	Conclusion . . . . .	87
<b>5</b>	<b>Intelligent Local Avoided Collision (<i>i</i>LAC) MAC Protocol</b>	<b>90</b>
5.1	Introduction . . . . .	91
5.2	Protocol description . . . . .	95
5.3	Analysis . . . . .	98
5.3.1	Simple example: $N = 2$ and $W = 3$ . . . . .	102
5.3.2	Small network examples . . . . .	103
5.4	Simulation . . . . .	103
5.5	Energy consumption . . . . .	110
5.6	Conclusion . . . . .	121
<b>6</b>	<b>Conclusion</b>	<b>125</b>
<b>A</b>	<b>List of academic achievements</b>	<b>130</b>

# List of Tables

1.1	Available spectrum for terrestrial mobile tech. in Asia Pacific Region	5
3.1	Markov states and transition probabilities . . . . .	58
3.2	Simulation Parameters . . . . .	65
3.3	Fairness Index . . . . .	68
4.1	Parameters Definition . . . . .	79
4.2	Simulation Parameters of 802.11 for Ns-2 . . . . .	83
4.3	Error between analytical model and simulation of 1 Station . . . . .	83
4.4	Error (%) between analytical model and simulation . . . . .	84
4.5	Throughput of 30 Station (54/6 Mbps) . . . . .	84
5.1	Markov's Parameters . . . . .	99
5.2	Comparison . . . . .	103
5.3	Simulation Parameters . . . . .	104
5.4	Simulation Parameters . . . . .	105
5.5	Power consumption of some 802.11b cards . . . . .	115

# List of Figures

1.1	Global mobile traffic during years 2008-2010 [2]	2
1.2	ITU traffic estimation in 2005 vs. reality [2]	3
1.3	Mobile global data traffic estimates from 2011 to 2015 [2]	4
2.1	Frequency assignment in FDMA system	10
2.2	Frame structure of TDMA system	11
2.3	Pure (unslotted) ALOHA channel	16
2.4	Slotted ALOHA channel	18
2.5	Through of ALOHA protocol	20
2.6	Local area network with bus architecture [2]	22
2.7	Through of non-persistent CSMA/CD protocol	24
2.8	Through of 1-persistent CSMA/CD protocol	25
2.9	$p$ -persistent CSMA/CD protocol	27
2.10	ALOHA vs. CSMA/CD protocols throughput comparison	27
2.11	ALOHA vs. CSMA/CD protocols throughput-delay comparison	28
2.12	An example of binary tree algorithm	32
2.13	Performance of tree algorithm [11]	34
2.14	Protocol stack [10]	35
2.15	Example of basic access mechanism	38
2.16	RTS/CTS access mechanism	39
2.17	FAWAC protocol	41

2.18	FAWAC performance ( $N = 100; W = 0, 25, 50, 75, 99; c = 0$ ) . . . . .	42
2.19	FAWAC performance ( $N = 100; W = 0, 25, 50, 75, 99; c = 1$ ) . . . . .	43
2.20	FAWAC performance ( $N = 100; W = 0, 25, 50, 75, 99; c = 2$ ) . . . . .	44
2.21	Delay-Throughput characteristics . . . . .	45
2.22	Channel arrangement . . . . .	46
2.23	Throughput of sequentially assigned power level protocol . . . . .	47
2.24	Throughput-Delay characteristic . . . . .	48
3.1	Structure of modified ACK . . . . .	55
3.2	Graphical presentation of continuous transmission . . . . .	56
3.3	Makov model of CAT . . . . .	57
3.4	Normalized throughput comparison ( $N=10$ ) . . . . .	66
3.5	Normalized throughput comparison ( $N=30$ ) . . . . .	66
3.6	Collision/Success Ratio ( $N=10$ ) . . . . .	67
3.7	Collision/Success Ratio ( $N=30$ ) . . . . .	67
3.8	Mean Length of Continuous Transmission . . . . .	68
4.1	Fragmentation process . . . . .	74
4.2	802.11 Fragments transmission process under erroneous channel . . . . .	74
4.3	One-ACK transmission process under erroneous channel . . . . .	74
4.4	ACK frame of One-ACK protocol . . . . .	77
4.5	Modified Markov Model . . . . .	78
4.6	Network Throughput ( $N = 1, \text{Data/Basic rate} = 24/6 \text{ Mbps}$ ) . . . . .	84
4.7	Network Throughput ( $N = 20, \text{Data/Basic rate} = 24/6 \text{ Mbps}$ ) . . . . .	85
4.8	Network Throughput ( $N = 10, \text{Data/Basic rate} = 54/6 \text{ Mbps}$ ) . . . . .	85
4.9	Network Throughput ( $N = 30, \text{Data/Basic rate} = 108/6 \text{ Mbps}$ ) . . . . .	86
4.10	Network Throughput ( $N = 30, \text{Data/Basic rate} = 432/54 \text{ Mbps}$ ) . . . . .	86
5.1	Overhead in 802.11 DCF . . . . .	92

5.2	Backoff decision in DCF . . . . .	93
5.3	Data frame structure . . . . .	94
5.4	ACK frame structure . . . . .	96
5.5	iLAC's transmission sequence . . . . .	97
5.6	Markov model . . . . .	99
5.7	Analysis vs Simulation Comparison . . . . .	104
5.8	Throughput/Delay Comparision . . . . .	106
5.9	Fairness Index . . . . .	107
5.10	Throughput Comparison . . . . .	109
5.11	Throughput Comparison . . . . .	110
5.12	Throughput Comparison . . . . .	110
5.13	Throughput Comparison (N=10, Frag. size = 256 Bytes) . . . . .	111
5.14	Throughput Comparison (N=10, Frame size = 2048 Bytes) . . . . .	111
5.15	Throughput Comparison (N=10, Frame size = 8192 Bytes) . . . . .	112
5.16	Throughput Comparison . . . . .	112
5.17	Throughput Comparison (N=10, Frame size = 64*256 Bytes) . . . . .	113
5.18	Throughput Comparision (Frame size = 64*256 Bytes) . . . . .	113
5.19	Throughput Comparison (hidden case) . . . . .	114
5.20	Analysis vs. Simulation Comparision for Throughput . . . . .	115
5.21	Energy per slot . . . . .	116
5.22	Energy per slot . . . . .	116
5.23	Effective energy . . . . .	117
5.24	Effective energy . . . . .	117
5.25	Wasteful energy . . . . .	118
5.26	Wasteful energy . . . . .	118
5.27	WLAN card D DCF Energy Structure . . . . .	119
5.28	WLAN card D iLAC Energy Structure . . . . .	119



5.29 Energy per bit . . . . .	120
5.30 Energy per bit . . . . .	120

# Chapter 1

## Introduction

The increasing popularity of the mobile devices in recent years has drawn much attention to basic research on wireless communications' technologies. With the explosion of the new digital age, wireless communication is no longer confined in simply radio broadcasting or mobile communication services. The wireless technology becomes increasingly important in our daily life.

### 1.1 The global traffic demand

The experience with mobile telephony though shows the potential for growth in the information and communication technology sector in developing countries [1]. Recently, the world observes the explosion of mobile traffic. The fast growth of mobile broadband access is observed in many countries around the world. ITU has to revise its forecast on the spectrum demand and mobile traffic increase. The fast development of mobile devices such as smart phones, laptops, tablet computers, become the main driving force for the traffic demand. The deployment of 3G networks and affordable subscription rate of various packages contribute to the popularity of the advanced data service.

Mobile communications and the the fast penetration of mobile broadband services have been playing significant roles in the economic and social developments of all countries. It is clear that mobile broadband has contributed considerably to the socio-economic development of individuals, commerce, and communities. According to World Bank report, 10% increase in broadband penetration contributes to economic growth about 1.38% [8]. In China, every 10% increase in broadband penetration is seen as contributing an additional 2.5% to GDP growth [7]. This finding is the most compelling fact that supports the fast development of mobile broadband services around the globe.

According to the latest version of new report of ITU-R [2], the global mobile broadband traffic and the number of subscriptions have dramatically increased in the last few years. Fig. 1.1 shows the growth in global mobile traffic, an increase of over two-and-a-half times (2.6-fold) in 2010. The number of global mobile subscriptions has increased from 3.9 billion in 2008 to 5.3 billion in 2010.

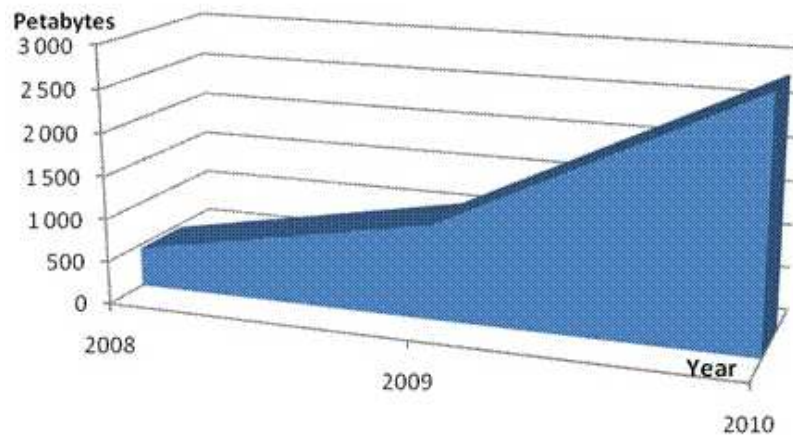

Figure 1.1: Global mobile traffic during years 2008-2010 [2]

The dramatic increase has been attributed by the introduction of new devices and business models. Mobile video traffic accounts for a large share of the mobile data traffic and this trend will continue to keep growing in the near future. The users are not just passively watching video in the internet such as YouTube but also uploading

home produced content to share with the community. The ease of using handheld devices to access and interact with internet environment will accelerate the amount of content growth at a larger rate. The 3D multimedia data is expected to play a significant share of mobile traffic in the future as well.

According to [2], over 300,000 mobile applications have been developed for smart phones during the period 2008-2010. The most used mobile applications are games, news, maps, social networking, music and more recently medical applications. Fig. 1.2 demonstrates the comparison of the forecast of ITU to the future development of mobile data traffic. The forecast for global traffic represented by M.2072 [3] is depicted by the blue area. The actual traffic, brown line, is taken from the CISCO report [4], and the reports forecast, red line, is also demonstrated to indicate how the traffic will involve in the near future. The dramatic fast growth of mobile data traffic reflects the dynamic of mobile communications industry. The actual global mobile traffic demand has far exceeded the forecast for WRC-07. The new forecast in [4] shows that mobile traffic demand will growth about 26 times in five year until 2015

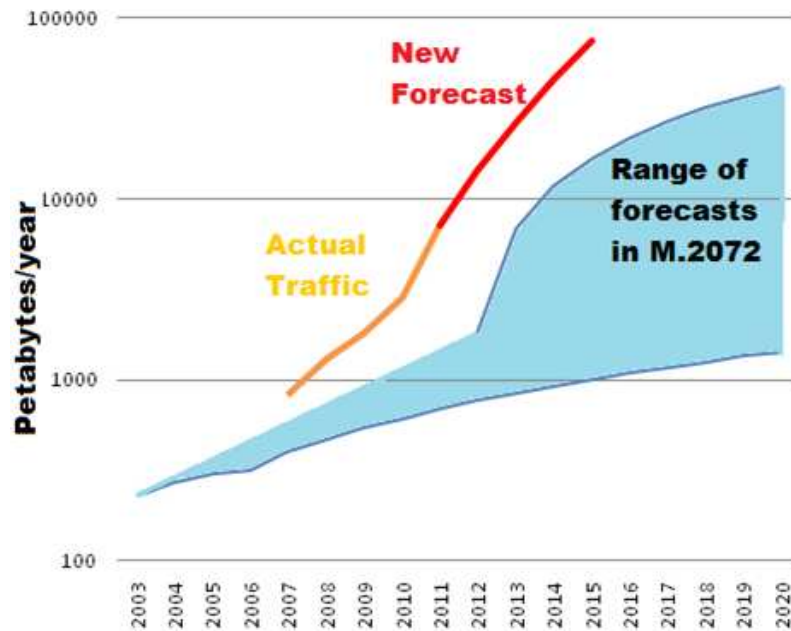

Figure 1.2: ITU traffic estimation in 2005 vs. reality [2]

The estimation of future data traffic is not the same from different organizations. Fig. 1.3 reflects such differences. Although, the trend of continuously increasing in mobile traffic is clear, the exact number of increment is quite different. One of the main reason is they use different sets of input data and assumption. In the short term, the estimations seem to be almost identical. With such huge demand, new technologies should be developed to handle such vast data volume growth.

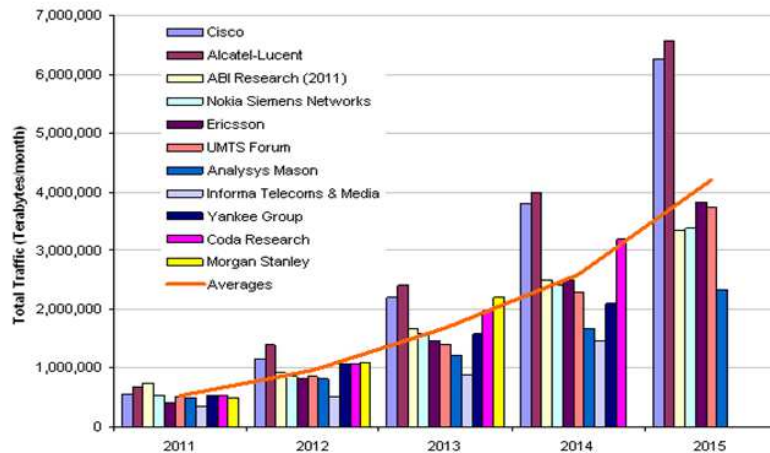

Figure 1.3: Mobile global data traffic estimates from 2011 to 2015 [2]

## 1.2 Possible solutions for mobile traffic growth

Mobile communications including mobile broadband communications have been playing very positive roles in the economic and social developments of both developed and developing countries. The impact of mobile communications to the economic growth, mitigation of digital divide, improvement of life quality, and facilitation of other industries has been recognized by governments and industries alike.

The main factor that regulates the capacity of mobile industry is the available of mobile spectrum. With the predicted mobile traffic demand in [3], ITU has predicted that the higher market would need 840 MHz of the total spectrum allocated to mobile operators by 2010. For lower market, the demand of spectrum is lower, 760 MHz [5].

Table 1.1: Available spectrum for terrestrial mobile technology in Asia Pacific Region [6]

Country	Bandwidth (MHz)
Australia	360
China	375
India	240
Japan	435.9
Republic of Korea	320
Vietnam	370.58
. . .	. . .
Average	383.5

However, the current available bandwidth in Asia Pacific region is approximately 383.5 MHz [6], far lower than the required spectrum. The bandwidth available for some countries in Asia Pacific region is given in Table 1.2.

With the current available bandwidth and current widely deployed mobile wireless networks using 2G and 3G technologies, we cannot handle such huge demand of mobile data traffic.

A fundamental solution to the problem is allocating new spectrum to mobile communication services. The spectrum is precious and limited resource that could not be allocated easily to mobile operators. Allocating new spectrum is time consuming and expensive process. Therefore to meet the future traffic demands, the mobile industries need to rely on the technical solutions to improve spectrum efficiency. The technical solutions may include:

- Migrating to mobile broadband network using enhanced IMT-2000 capability such as: WCDMA/HSPA, HSPA+; WiMAX, LTE, LTE-advanced, . . . ;
- Network optimization such as using small cells deployment instead of larger cells;
- Offload intensive mobile traffic to fixed broadband network, using technologies such as: femto-cell, WiFi, ...

It becomes obvious that offloading traffic solution is the most economical means to address the high volume traffic demand for mobile broadband network. The research in this thesis focuses mainly on the designing better transmission protocol for WiFi network to support high performance data transmission for wireless communications.

### **1.3 The role of Medium Access Control (MAC)**

A wireless network consists of wireless nodes. Each node has the ability to transmit and receive radio signals. Similar to the wired network, the wireless network architecture has a layered structure. The lowest layer is the physical layer. The transmission methods and technologies are governed by this layer. The MAC sits directly on top of the physical layer. The main function of MAC is to control the accessibility of the radio medium. It controls when, how, and who should transmit data.

MAC protocols play vital role in the communications systems. The design of MAC protocol for wireless networks is becoming increasingly difficult because the wireless environment is very different from the wired environment, and hence the design of a MAC protocol must take into account the problems specific to a wireless environment.

The main objectives for MAC design are robustness, scalability, throughput improvement, energy efficiency. Other less stringent criteria included fairness and delay reduction. The current MAC protocols have not fully deliver the very high speed data transmission that the physical layer now offers. An efficient MAC operation is required and open for active researches in this area.

WLAN 802.11 wireless MAC protocol has drawn much attention in recent years. The protocol is simple, yet very effective for the typical WLAN environment. This protocol is easy to implement, simple in operation and aim to work in distributed networks as well as QoS guarantee networks.

Although 802.11 MAC protocol has many advantages and widely accepted, its operations reveal several weak points that need to be addressed in order to support high performance wireless communication system. The typical working environment of WLAN system is for small area communications. Therefore the MAC protocol should take this special characteristic into account to boost the system transmission speed toward maximum achievable level.

In this thesis, we proposed new access schemes for wireless communication, especially for WLAN environment in high traffic and large population conditions. The proposed protocol solutions are superior to the basic 802.11 MAC protocol in many measures: throughput, delay and power consumption. These solutions have high potential to apply to the current WLAN network with little modification in the firm ware.

## **1.4 Thesis Layout**

This thesis presents a study of medium access control in telecommunications networks. A survey of previous access schemes will be discussed in Chapter 2. In Chapter 3, the developments of 802.11 protocol are studied extensively. Many issues are required to be taken into consideration when designing a wireless MAC protocol, such as the characteristics of the wireless medium and the packet sizes distribution of real traffic. Chapter 4 is continuous transmission protocol (Globecom paper). Chapter 5 describes the one ACK protocol. Chapter 6 describe iLAC protocol in detail. Chapter 7 draws conclusion of this thesis and discusses the future development directions.



# Bibliography

- [1] Y. Kim, T. Kelly, S. Raja, Building broadband Strategies and policies for developing world, World Bank Publications, Jun. 2010.
- [2] ITU-R M.[IMT.UPDATE] - Assessment of the global mobile broadband deployments and forecasts for IMT, WP5D, ITU-R, Oct. 2011.
- [3] Report ITU-R M.2072, World mobile telecommunication market forecast, 2005.
- [4] Visual Networking Index: Global Mobile Data traffic Forecast Update 2010-2015, Cisco 2011.
- [5] Report ITU-R M.2078, Estimated spectrum bandwidth requirements for the future development of IMT-2000 and IMT-Advanced, 2006
- [6] White Paper on forecast of mobile broadband development in the Asia Pacific Region, CJK IMT Working Group, AWG11, Sep 2011.
- [7] Broadband: A platform for progress, ITU/UNESCO, Jun 2011.
- [8] Information and Communications for Development 2009: Extending Reach and Increasing Impact, World Bank 2009.

# Chapter 2

## Multiple Access Techniques

In this chapter we review relevant MAC protocols that will serve as foundation to our research.

### 2.1 Introduction to multiple access techniques

Multiple access technology deals with systems in which a large number of users share a common communication channel to transmit information to a receiver. The common channel maybe the uplink in a satellite communication system, or a cable to which are connected a set of terminals that access a central computer, or some frequency band in the radio spectrum that is used by multiple users to communicate with a radio receiver.

In this chapter we survey several access schemes in which many users can access to a common channel to transmit or receive information. The multiple access methods that are described in this chapter form the basic for current and future wireline and wireless communication networks, such as satellite networks, cellular and mobile communication networks, ... [2].

## 2.2 Frequency Division Multiple Access (FDMA)

In general, there are several different ways in which multiple users can send information through the communication channel to the receiver. One simple method is to subdivide the available channel bandwidth into a number, say  $K$ , of frequency non-overlapping subchannels, as shown in Fig. 2.1, and to assign a subchannel to each user upon request by the users. This method is generally called frequency-division multiple access (FDMA) and is commonly used in wireline and wireless channels to accommodate multiple users for voice and data transmission [2].

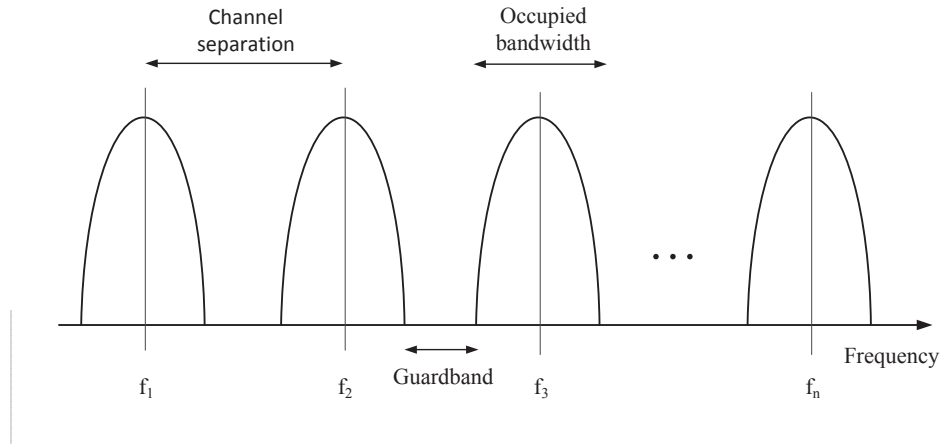

Figure 2.1: Frequency assignment in FDMA system

If a channel, such as a cable, has a transmission bandwidth  $W$  Hz, and individual users require  $B$  Hz to achieve their required information rate, then the channel in theory should be able to support  $W/B$  users simultaneously by using bandpass modulation, and placing each user in an adjacent slot of the available bandwidth [3].

FDMA allows completely uncoordinated transmissions in the time domain: no time-synchronization among users is required [21] as in the next multiple access scheme.

## 2.3 Time Division Multiple Access (TDMA)

Another method for creating multiple subchannels for multiple access is to subdivide the duration  $T_f$ , called the frame duration, into, say,  $N$  non-overlapping subintervals, each of duration  $T_f/N$ . Then each user who wishes to transmit information is assigned to a particular time slot within each frame. This multiple access method is called time-division multiple access (TDMA) and it is frequently used in data and digital voice transmission [2].

We assume here that each packet to be transmitted fits into one time slot. All transmitters are synchronized so that the reception of each transmission starts at the beginning of a time slot and ends at the end of this time slot. Such synchronization is usually not too difficult if one is given a small guard space between packets, and stable clocks [1].

In the Fig. 2.2 we can see that, if station  $N$ , for example, has a new arrival packet to transmit at time slot 2, that packet will have to wait until assigned time slot  $N$  to transmit.

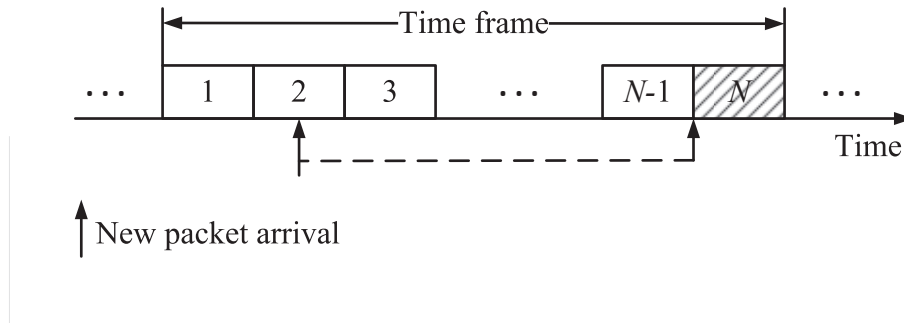

Figure 2.2: Frame structure of TDMA system

TDMA is a prominent technique for accessing a communication channel. Although TDMA is effective in situations where the number of sources is small and the message lengths are long, it suffers from a large average delay when the number of sources is large and the frame length,  $T_f$ , is short [11].

We observe that in FDMA and TDMA, the channel is basically partitioned into independent single-user subchannels. In this sense, the communication system design methods for single-user communication are directly applicable and no new problems are encountered in a multiple access environment, except for the additional task of assigning users to available channels.

For multiaccess channels, on the other hand, most transmitters have nothing to send most of the time, and only a few are busy. The problem is then to share the channel between the busy users, and this is often the central technical problem in multiaccess communication [1].

For this common type of environment, a fixed allocation of channel time/bandwidth to each station is wasteful of resources [15] because a certain percentage of the available frequency slots or time slots assigned to users do not carry information. Ultimately, an inefficiently designed multiple access system limits the number of simultaneous users of the channel.

## 2.4 Code Division Multiple Access (CDMA)

An alternative to FDMA and TDMA is to allow more than one user to share a channel or subchannel by use of direct-sequence spread spectrum signals. In this method, each user is assigned a unique code sequence or *signature sequence* that allows the user to spread the information signal across the assigned frequency band. Thus signals from the various users are separated at the receiver by cross correlation of the received signal with each of the possible user signature sequences. By designing these code sequences to have relatively small cross-correlations, the crosstalk inherent in the demodulation of the signals received from multiple transmitters is minimized. This multiple access method is called *Code Division Multiple Access* (CDMA).

In CDMA, the users access the channel in a random manner. Hence, the signal transmissions among the multiple users completely overlap both in time and in frequency. Because several sources can transmit at once using different modulating sequences, each will look like broadband noise to the others [1]. The demodulation and separation of these signals at the receiver is facilitated by advanced digital signal processing. CDMA is sometimes called spread spectrum multiple access (SSMA).

CDMA provides an automatic solution to the problem of allocating the channel to the busy users. This solution is not entirely satisfactory, since one still needs collision resolution when too many transmitters send at once, and the decoding is very complex [1].

An alternative to CDMA is nonspread random access. In such a case, when two or more users attempt to use the common channel simultaneously, their transmissions collide and interfere with each other. When that happens, the information is lost and must be retransmitted. To handle collisions, one must establish protocols for retransmission of messages that have collided.

The collision resolution approach to multiaccess communication focuses on allocating the channel among a large set of users at different transmitting sites. When studying multi-access technology, we adopt some assumptions:

1. *Collision or Perfect Reception:* We assume that if more than one transmitter sends a packet then there is a collision and the receiver gets no information about the contents or origins of the transmitted packets. If just one transmitter sends a packet, it will be received with no errors. This assumption that removes the noise and communication aspects from the problem; it allows collision resolution to be studied in the simplest context.
2. *Poisson Arrivals:* Assume that new packet arrivals are Poisson at an overall rate  $\lambda$  [packets/second]. This is reasonable, given independent arrival processes at the individual nodes.

3.  $(0, 1, c)$  *Feedback*: Assume that by the end of transmission, each transmitter learns whether 0 packets, 1 packet, or more than one packet ( $c$  for collision) were transmitted. The assumption of  $(0, 1, c)$  feedback implies that the receiver (or the transmitters themselves) can distinguish between an idle slot and a collision. It also implies that idle transmitters can understand this feedback [1].

There are many channel access protocols that can be used to handle collisions. The access methods described below are basically random, because packets are generated according to some statistical model. Users access the channel when they have one or more packets to transmit. When more than one user attempts to transmit packets simultaneously, the packets overlap in time, i.e., they collide, and hence, we need an efficient mechanism to solve this problem. In the following sections we describe several random access channel protocols that resolve conflicts in packet transmission.

## 2.5 ALOHA Systems and Protocols

Suppose that a random access scheme is employed where each user transmits a packet as soon as it is generated. When a packet is transmitted by a user and no other user transmits a packet for the whole transmission duration, then the packet is considered successfully transmitted. However, if one or more of the other users transmits a packet that overlaps in time with the packet from the first user, a collision occurs and the transmission is unsuccessful. Fig. 2.3 illustrates this scenario. If the users know when their packets are transmitted successfully and when they have collided with other packets, it is possible to devise a scheme, which we may call a channel access protocol, for retransmission of collided packets.

Feedback to the users regarding the successful or unsuccessful transmission of packets is necessary and can be provided in a number of ways. In a radio broadcast system, such as one that employs a satellite relay, the packets are broadcast to all the

users on the downlink. Hence, all the transmitters can monitor their transmissions and, thus, obtain the following ternary information: no packet was transmitted, or a packet was transmitted successfully, or a collision occurred. This type of feedback to the transmitters is generally denoted as  $(0, 1, c)$  feedback.

The ALOHA system devised by Abramson [19] and others at the University of Hawaii employs a satellite repeater that broadcasts the packets received from the various users who access the satellite. The idea here was that whenever a packet arrived at a transmitter, it would simply be transmitted, ignoring all other transmitters in the network. If another transmitter was transmitting in an overlapping interval, interference would prevent the message from being correctly received, the cyclic redundancy check (CRC) would not check, no acknowledgement would be sent, and the transmitter would try again later; the later time would be pseudorandomly chosen to avoid the certainty of another collision if both transmitters waited the same time. Over the years, this basic strategy has been improved, generalized, and analyzed in many ways [1].

There are basically two types of ALOHA systems: unslotted/pure and slotted ALOHA.

### **2.5.1 Unslotted ALOHA**

In an unslotted ALOHA system, a user may begin transmitting a packet immediately upon arrival. Whenever a collision occurs each packet involved in the collision is said to be backlogged and remains backlogged until it is successfully retransmitted. In pure ALOHA backlogged packets are retransmitted after an exponentially distributed delay.

We assume that the start time of packets that are transmitted is a Poisson point process having an average rate of  $\lambda$  packets/s. Let  $T_p$  denote the time duration of a packet. Then, the normalized channel traffic  $G$ , also called the offered channel traffic,



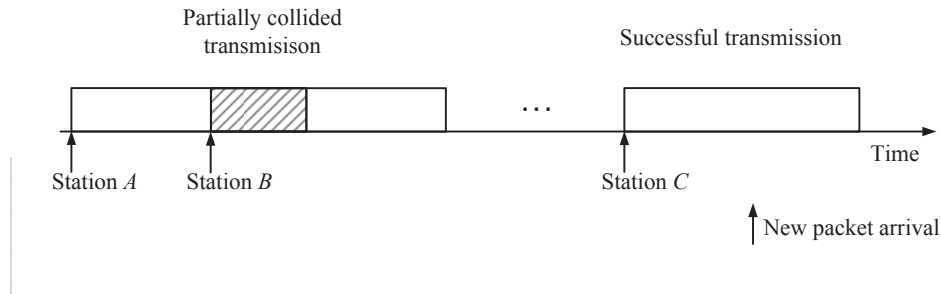

Figure 2.3: Pure (unslotted) ALOHA channel

is defined as:

$$G = \lambda T_p \tag{2.1}$$

In general  $G$  can be greater than 1.0.

In unslotted ALOHA protocol, packets that have collided are retransmitted with some delay  $\tau$ , where  $\tau$  is randomly selected according to a predefined PDF function:

$$p(\tau) = \alpha e^{-\alpha\tau} \tag{2.2}$$

where  $\alpha$  is a design parameter. The random delay  $\tau$  is added to the time of the initial transmission and the packet is retransmitted at the new time. If a collision occurs again, a new value of  $\tau$  is randomly selected and the packet is retransmitted with a new delay from the time of the second transmission. This process is continued until the packet is transmitted successfully. The design parameter  $\alpha$  determines the average delay between retransmissions. The smaller the value of  $\alpha$ , the longer the delay between retransmissions [2].

### Throughput for unslotted ALOHA

We can relate the channel throughput  $S$  to the offered channel traffic  $G$  by use of the assumed start time distribution. The probability that a packet will not overlap a given packet is simply the probability that no packet begins  $T_p$  seconds before

or  $T_p$  seconds after the start time of the transmitted packet. Since the start time of all packets is Poisson-distributed, and suppose that the system followed renewal model, the probability that a packet will not overlap is  $e^{-2\lambda T_p} = e^{-2G}$ . Therefore, the normalized channel throughput is:

$$S = Ge^{-2G} \tag{2.3}$$

This relationship is plotted in Fig. 2.5. We observe that the maximum throughput is  $S_{max} = \frac{1}{2}e = 0.184$  packets per slot, which occurs at  $G = 1/2$ . When  $G > 1/2$ , the throughput  $S$  decreases. The above development illustrate that an unslotted random access method has a relatively small throughput and is inefficient.

One advantage of pure (unslotted) ALOHA is that it can handle different packet length.

## 2.5.2 Slotted ALOHA

Slotted ALOHA is a variation of pure ALOHA. Channel is partition into slot. Transmission is only allowed at the beginning of a time slot and the duration of a time slot is equal to the time for one packet. In slotted ALOHA, whenever a packet arrives at one of the transmitters, that packet is transmitted in the next time slot. Backlogged packet is retransmitted in each subsequent slot with some fixed probability  $p > 0$ , independent of past slots and of other packets [1]. There are only full collisions in Slotted ALOHA as depicted in Fig. 2.4.

### Throughput for slotted ALOHA

To determine the throughput in a slotted ALOHA system, let  $G_i$  be the probability that the  $i_{th}$  user will transmit a packet in some slot. If all the  $K$  users operate independently and there is no statistical dependence between the transmission of the

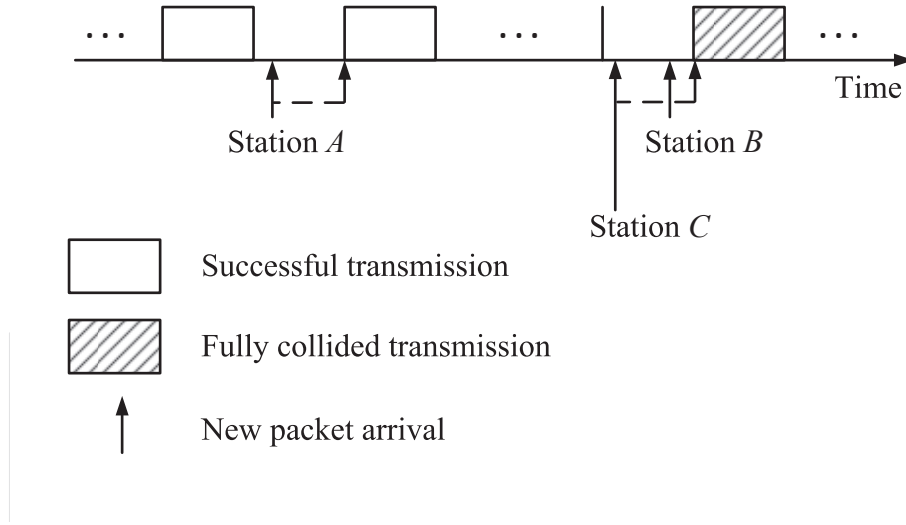

Figure 2.4: Slotted ALOHA channel

user's packet in the current slot and the transmission of the user's packet in previous time slots, the total (normalized) offered channel traffic is

$$G = \sum_{i=1}^K G_i \quad (2.4)$$

Now, let  $S_i \leq G_i$  be the probability that a packet transmitted in a time slot received without a collision. Then, the normalized channel throughput is

$$S = \sum_{i=1}^K S_i \quad (2.5)$$

The probability that a packet from the  $i_{th}$  user will not have a collision with another packet is

$$Q_i = \prod_{j=1; j \neq i}^K (1 - G_j) \quad (2.6)$$

Therefore,

$$S_i = G_i Q_i \quad (2.7)$$

A simple expression for the channel throughput is obtained by considering  $K$  identical users. Then

$$S_i = \frac{S}{K}; \quad G_i = \frac{G}{K} \quad (2.8)$$

and

$$S = G \left(1 - \frac{G}{K}\right)^{K-1} \quad (2.9)$$

Then, if we let  $K \rightarrow \infty$ , we obtain the system throughput:

$$S = G e^{-G} \quad (2.10)$$

This result is also plotted in Fig. 2.5. We observe that  $S$  reaches a maximum throughput of  $S_{max} = \frac{1}{e} = 0.368$  packets per slot at  $G = 1$ , which is twice the throughput of the unslotted ALOHA system. That is because in unslotted ALOHA, most of the collisions are partial collisions, but in slotted ALOHA system, only totally collisions occurred. Because of that fact, slotted ALOHA can produce higher throughput comparing to unslotted ALOHA.

The performance of the slotted ALOHA system given above is based on Abramson's protocol for handling collisions. Unslotted/slotted ALOHA protocols become basic multiple access protocols. A higher throughput is possible by devising a better protocol [16], [3], [11], ...

In addition to throughput, another important performance measure in random access system is the average transmission delay. In an ALOHA system, the parameter  $\alpha$  determines the average delay between retransmissions. If we select  $\alpha$  small, we obtain the desirable effect of smoothing out the channel load at times of peak loading, but the result is a long retransmission delay. This is the trade-off in the selection of  $\alpha$  in Equation (2.2).

Another important issue in the design of random access protocols is the stability of the protocol. In ALOHA channel access protocols, we can see that, when the

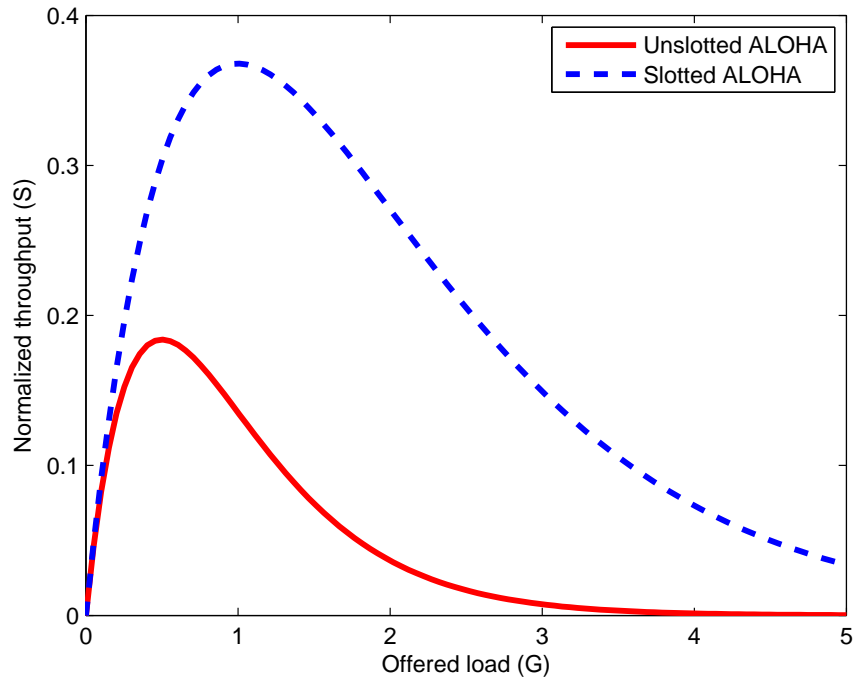

Figure 2.5: Through of ALOHA protocol

offer load  $G$  small, the throughput  $S$  increase together with  $G$ . But when  $G$  reach to a certain level,  $G = 1$  as in case of slotted ALOHA, further increase in  $G$  results in decrease in  $S$  exponentially and the delay may become extremely large. By this natural, this multiple access protocol is called unstable.

In fact, it can be demonstrated that any channel access protocol, such as the ALOHA protocol, that does not take into account the number of previous unsuccessful transmissions in establishing a retransmission policy is inherently unstable [2].

Despite the instability of slotted ALOHA, it can still be a useful collision resolution approach, especially if the system is modified to avoid or recover from the heavily backlogged state [1].

## 2.6 Carrier Sense Systems and Protocols

As we have observed in the previous section, ALOHA-type (slotted and unslotted) random access protocols yield relatively low throughput. Furthermore, a slotted ALOHA system requires that users transmit at synchronized time slots. In channel where transmission delays are relatively small, it is possible to design random access protocols that yield higher throughput. An example of such a protocol is carrier sensing with collision detection, which is used as a standard Ethernet protocol in local area networks. This protocol is generally known as Carrier Sense Multiple Access with Collision Detection (CSMA/CD) [2].

Carrier Sense Multiple Access (CSMA) techniques was first developed by Kleinrock and Tobagi [20]. The terminology "carrier sense" does not necessarily imply the use of a carrier, but simply the ability to quickly detect use of the channel [1].

The CSMA/CD protocol is simple. All users listen for transmissions on the channel. A user who wishes to transmit a packet seizes the channel when it senses that the channel is idle. Collisions may occur when two or more users sense an idle channel and begin transmission. When the users that are transmitting simultaneously sense a collision, they transmit a special signal, called a jam signal, that serves to notify all users of the collision and abort their transmissions. Both the carrier sensing feature and the abortion of transmission when a collision occurs result in minimizing the channel waste and, hence, yield a higher throughput.

To elaborate on the efficiency of CSMA/CD, let us consider a local area network having a bus architecture, as shown in Fig. 2.6. Consider two users  $U_1$  and  $U_2$  at the maximum separation, i.e., at the two ends of the bus, and let  $\tau_d$  be the propagation delay for a signal to travel the length of the bus. Then, the (maximum) time required to sense an idle channel is  $\tau_d$ . Suppose that  $U_1$  transmits a packet of duration  $T_p$ . User  $U_2$  may seize the channel  $\tau_d$  seconds later by using carrier sensing and begins to transmit. However, user  $U_1$  would not know of this transmission until  $\tau_d$  seconds after

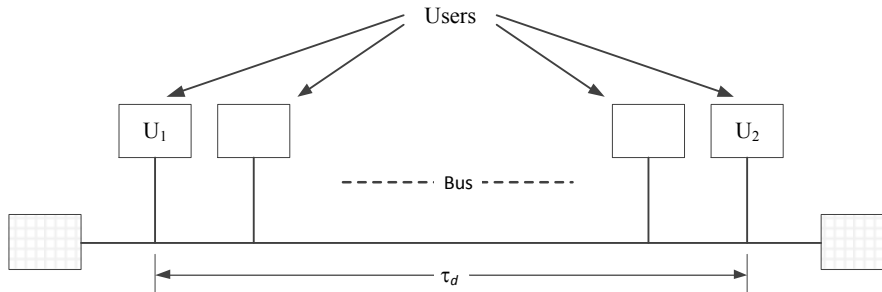

Figure 2.6: Local area network with bus architecture [2]

$U_2$  begins transmission. Hence, we may define the time interval  $2\tau_d$  as the (maximum) time interval to detect a collision. If we assume that the time required to transmit the jam signal is negligible, the CSMA/CD protocol yields a high throughput when  $2\tau_d \ll T_p$ .

There are several possible protocols that may be used to reschedule transmissions when a collision occurs. One protocol is called nonpersistent CSMA, a second is called 1-persistent CSMA, and a generalization of the latter is called  $p$ -persistent CSMA.

### 2.6.1 Nonpersistent CSMA

The core idea is to limit the interference among packets by always rescheduling a packet which finds the channel busy upon arrival. In this protocol, a user that has a packet to transmit senses the channel and operates according to the following rules:

1. If the channel is idle, the user transmits a packet.
2. If the channel is sensed busy, the user schedules the packet retransmission at a later time according to some delay distribution. At the end of the delay interval, the user again senses the channel and repeats steps (1) or (2).

The basic throughput of nonpersistent CSMA is a function of propagation delay related to packet transmission time  $a$  and offered load  $G$  as the following:

$$S = \frac{Ge^{-aG}}{G(1+2a) + e^{-aG}} \quad (2.11)$$

A slotted version of the nonpersistent CSMA can be constructed in which the time axis is slotted and the slot size is  $\tau$  seconds (the propagation delay). All stations are synchronized and forced to transmit at the beginning of a time slot. The terminal senses the channel at the beginning of the next slot and operates according to the protocol described above [20].

$$S = \frac{aGe^{-aG}}{(1 - e^{-aG}) + a} \quad (2.12)$$

Where the parameter  $a = \tau/T$ .

$T$ : packets transmission time, assumed that all packets are equal lengths.

$\tau$ : maximum propagation delay.

When  $a \rightarrow 0, S \rightarrow G/(1+G)$ . Fig. 2.7 illustrates the throughput versus the offered traffic  $G$ , with  $a$  as a parameter. We observe that  $S \rightarrow 1$  as  $G \rightarrow \infty$  for  $a = 0$ . For  $a > 0$  the value of  $S_{max}$  decrease. The results show that nonpersistent CSMA protocol is sensitive to delay.

## 2.6.2 1-persistent CSMA

This protocol is designed to achieve high throughput by never allowing the channel to go idle if some user has a packet to transmit. Hence, the user senses the channel and operates according to the following rules:

1. if the channel is sensed idle, the user transmits the packet with probability 1.



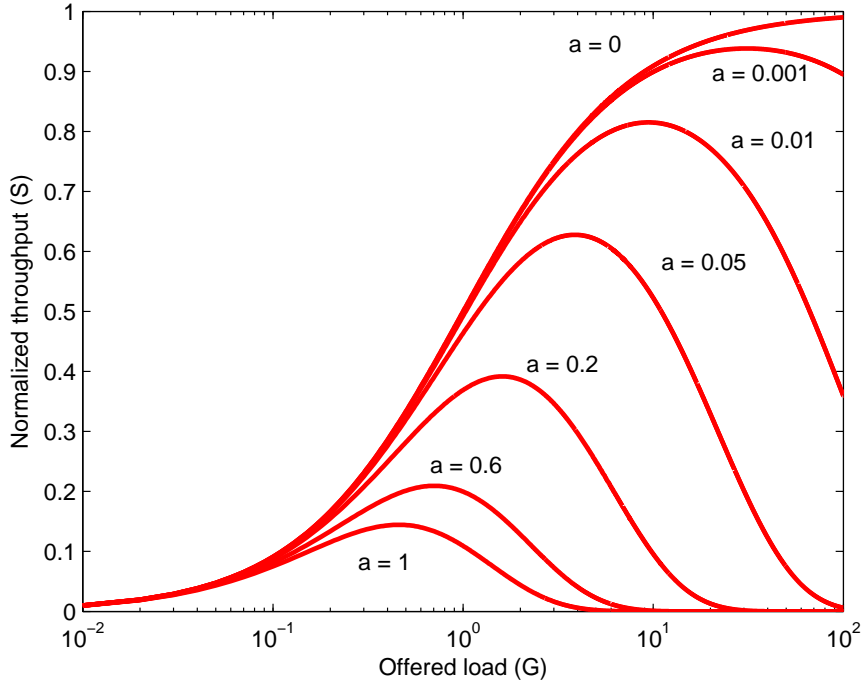

Figure 2.7: Through of non-persistent CSMA/CD protocol

2. If the channel is sensed busy, the user waits until the channel becomes idle and transmits a packet with probability one. Note that in this protocol, a collision will always occur when more than one user has a packet to transmit.

A slotted version of 1-persistent CSMA can also be constructed as in the non-persistent CSMA case.

For the 1-persistent protocol, the throughput obtained by Kleinrock and Tobagi in [20] is:

$$S = \frac{G [1 + G + aG(1 + G + \frac{1}{2}aG)] e^{-G(1+2a)}}{G(1 + 2a) - (1 - e^{-aG}) + (1 + aG)e^{-G(1+a)}} \quad (2.13)$$

For slotted version of this protocol, the throughput becomes:

$$S = \frac{Ge^{-G(1+a)} [1 + a - e^{-aG}]}{(1 + a)(1 - e^{-aG}) + ae^{-G(1+a)}} \quad (2.14)$$

In case of  $a = 0$ , both slotted and unslotted version of 1-persistent CSMA are:

$$\lim_{a \rightarrow 0} S = \frac{G(1+G)e^{-G}}{G + e^{-G}} \quad (2.15)$$

which has a smaller peak value than the nonpersistent protocol.

Fig. 2.8 shows the performance of 1-persistent CSMA. We can see that 1-persistent CSMA gets lower performance comparing to nonpersistent CSMA.

The above 1-persistent CSMA and nonpersistent CSMA differ by the probability of not rescheduling a packet which upon arrival finds the channel busy. In the case of 1-persistent CSMA, if more than one packet arrive when the channel is busy then a collision always happen when the channel goes idle. By this shortcoming, we introduce  $p$ -persistent CSMA.

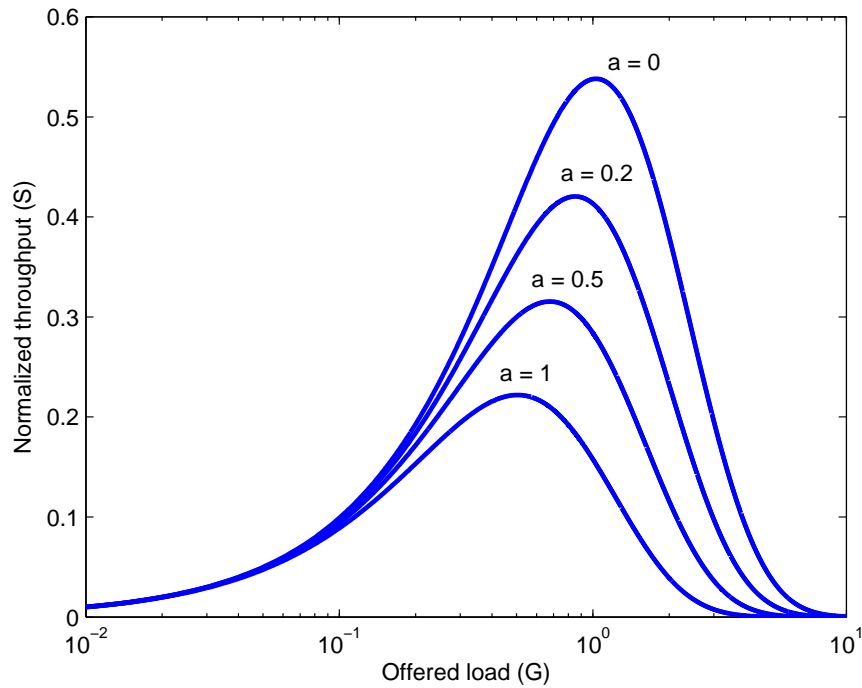

Figure 2.8: Through of 1-persistent CSMA/CD protocol

### 2.6.3 $p$ -persistent CSMA

To reduce the rate of collisions in 1-persistent CSMA and increase the throughput, we should randomize the starting time for transmission of packets. In particular, upon sensing that the channel is idle, a user with a packet to transmit sends it with probability  $p$  and delays it by  $\tau$  with probability  $1 - p$ . The probability  $p$  is chosen in a way that reduces the probability of collisions while the idle periods between consecutive (non-overlapping) transmissions is kept small. This is accomplished by subdividing the time axis into minislots of duration  $\tau$  and selecting the packet transmission at the beginning of a minislot. In summary, in the  $p$ -persistent protocol, a user with a packet to transmit proceeds as follows.

1. If the channel is sensed idle, the packet is transmitted with probability  $p$ , and with probability  $1 - p$  the transmission is delayed by  $\tau$  seconds.
2. If at  $t = \tau$ , the channel is still sensed to be idle, step 1) is repeated. If a collision occurs, the users schedule retransmission of the packets according to some preselected transmission delay distribution.
3. If at  $t = \tau$ , the channel is sensed busy, the user waits until it becomes idle, and then operates as in steps 1) and 2) above.

Slotted versions of the above protocol can also be constructed. Fig. 2.9 illustrates  $p$ -persistent protocol. When station  $A$  has data to send, it will send the channel at the beginning of next slot. At this time, the channel is idle, station  $A$  immediately sends the packet with probability  $p$ . Station  $B$  has a new packet while station  $A$  is transmitting. In this case, station  $B$  will sense channel busy and he has to wait until the channel become idle, after that it will reschedule its transmission following the procedure described above.

By adopting the  $p$ -persistent protocol, it is possible to increase the throughput relative to the 1-persistent scheme. For example, Fig. 2.10 illustrates the throughput

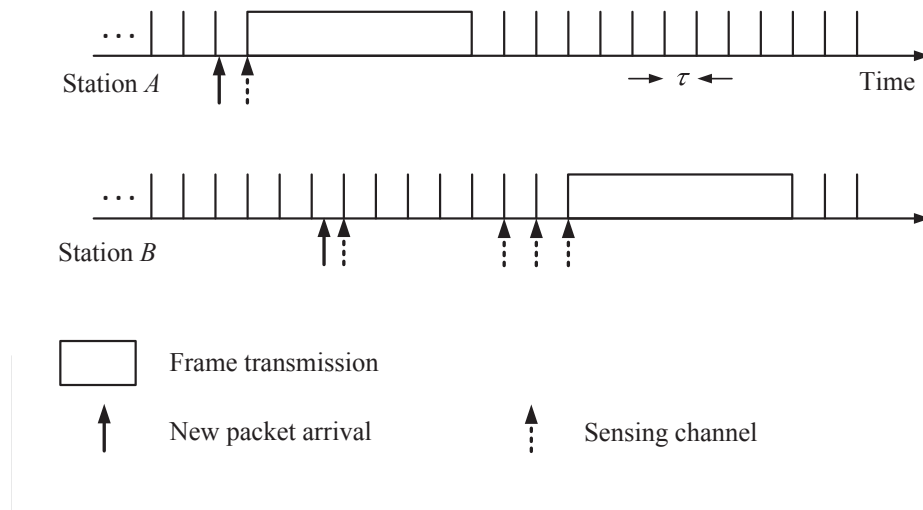

Figure 2.9:  $p$ -persistent CSMA/CD protocol

versus the offered traffic with a fixed and with  $p$  as a parameter. We observe that as  $p$  increases toward unity, the maximum throughput decreases.

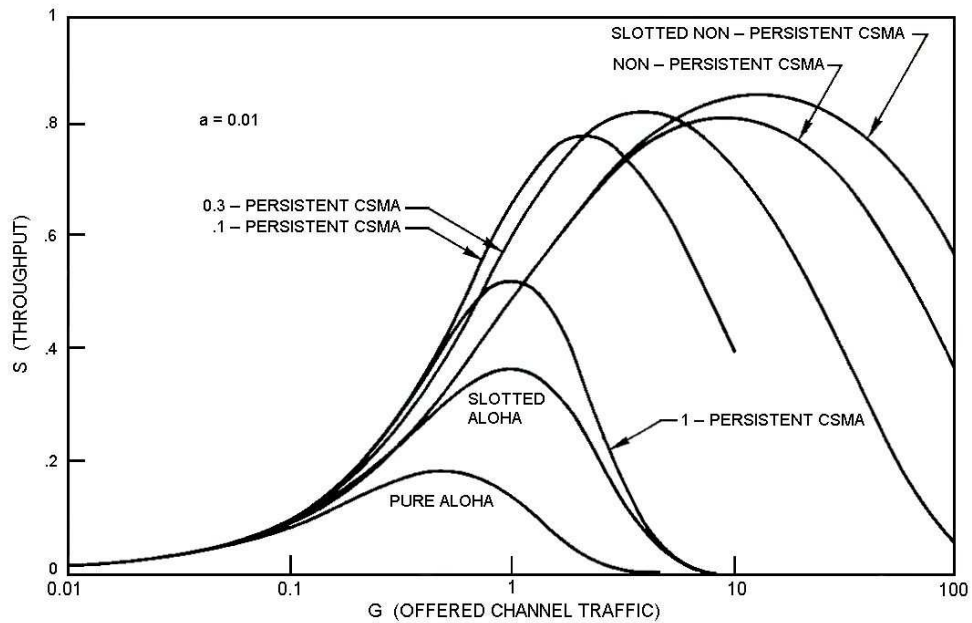

Figure 2.10: ALOHA vs. CSMA/CD protocols throughput comparison  
ALOHA vs. CSMA/CD protocols throughput comparison ( $a = 0.01$ ) [20]

The transmission delay was also evaluated by Kleinrock and Tobagi (1975). Fig. 2.11 illustrates the graphs of the delay (normalized by  $T_p$ ) versus the throughput

$S$  for the slotted nonpersistent and  $p$ -persistent CSMA protocols. Also shown for comparison is the delay versus throughput characteristic of the ALOHA slotted and unslotted protocols. In this simulation, only the newly generated packets are derived independently from a Poisson distribution. Collisions and uniformly distributed random retransmissions are handled without further assumptions. These simulation results illustrate the superior performance of the  $p$ -persistent and the nonpersistent protocols relative to the ALOHA protocols. The graph label "optimum  $p$ -persistent" is obtained by finding the optimal value of the throughput. We observe that for small values of the throughput, the 1-persistent ( $p = 1$ ) protocol is optimum.

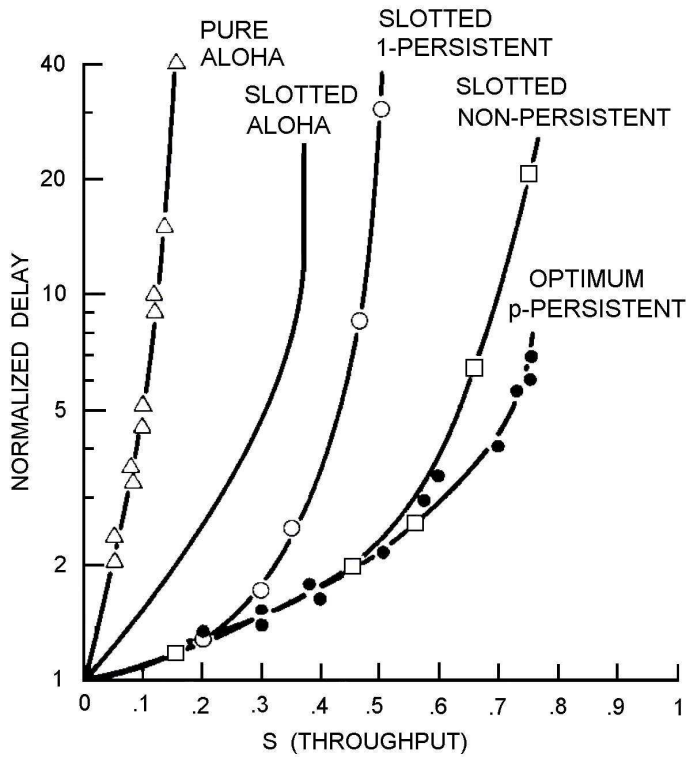

Figure 2.11: ALOHA vs. CSMA/CD protocols throughput-delay comparison ( $a = 0.01$ ) [20]

## 2.7 Tree Algorithm

The multiple access tree algorithm is first introduced by Capenatanakis [11] and by Tsybakov and Mikhailov [13] and then later is referred as Capenatakis, Tsybakov and Mikhailov algorithm [14]. This contention tree algorithm provides an efficient scheme for multiple accessing a broadcast communication channel.

The system considered here consists of  $2^N$  sources that independently generate packets to be transmitted over a slotted channel. The chosen of  $2^N$  is for simplification reason.

When the tree protocol is applied to such a system, a user is essentially free to transmit a packet in any slot until a collision occurs. When a collision occurs, packet transmissions are controlled until it is resolved. The collision is resolved by dividing all the users into several groups and assigning a slot for retransmission to each group. Any one of these new groups may contain zero, one, or more than one of the contending packets. If, by chance, the subdivisions are such that each group contains at most one user with a packet, then the initial collision is resolved.

If, on the other hand, multiple packets are assigned to any group, then a collision will reoccur. In such a case, the groups with conflicts are again subdivided into smaller groups and new slots are reassigned. This process of dividing and subdividing continues until all retransmissions result either in a packet being transmitted or in an empty slot. At worst, this process will continue until each user is assigned a unique slot.

If a group with a conflict is divided into two equal subgroups, then the resulting algorithm is the basic binary tree protocol.

### 2.7.1 Statistic binary tree

The stations will be divided by half to form two group called group  $A$  and group  $B$ .

The binary tree algorithm is as follows:

1. Transmit all the packets in group  $A$  in the first slot of the present pair of slots, and transmit all the packets in group  $B$  in the second slot.
2. If any collisions occur in the preceding step, then:
  - Until these collisions are resolved, do not transmit any new packets.
  - Resolve the first collision (if any) before resolving the second (if any).

A collision in group  $A$  (or  $B$ ) is resolved by dividing group  $A$  (or  $B$ ) into two halves (say  $A$  and  $B$ ), setting  $A=A$ ,  $B = B$ , and then repeating steps 1 and 2.

*Example:* Let there be 16 sources  $S_0, S_1, \dots, S_{15}$  and let each correspond to a leaf on the 16-leaf binary tree as shown in Fig. 2.11(a). Figure 2.11(b) depicts the slotted satellite times.

The slots are paired and that a slot pair is designated by  $SL_{ij}$ . For convenience, the round-trip delay  $\tau$  is taken as zero. If  $\tau > 0$ , then the slot pairs would be separated by at least  $\tau$ .

Assume that no collisions have occurred until the beginning of  $SL_{00}$ , when sources  $S_0, S_2, S_4, S_8$ , and  $S_{10}$  have a packet to transmit. Then beginning with  $SL_{00}$ , where the first contention arises, the tree algorithm takes the following steps:

- $SL_{00}$  All the sources in the first group that have packets to transmit (i.e.,  $S_0, S_2$  and  $S_4$ ) will transmit their packets in the first slot of  $SL_{00}$ , and the corresponding sources in second group follow. This results in two collisions, one among  $S_0, S_2$ , and  $S_4$  and the other between  $S_8$  and  $S_{10}$ . Since there are collisions in  $SL_{00}$ , any new arrival packets will have to wait until that collisions are resolved.

- $SL_{10}$  Since there was a collision stations  $S_0$ ,  $S_2$  and  $S_4$  are divided in half and the packets of  $(S_0, S_2)$  and  $(S_4)$  are transmitted in the first and second slots of  $SL_{10}$ , respectively. This results in a collision between  $S_0$  and  $S_2$  and in a successful transmission of  $S_4$ .
- $SL_{20}$   $S_0$  and  $S_2$  are allowed to transmit their packets in the first and second slots of  $SL_{20}$ , respectively. This results in two successful transmissions by  $S_0$  and  $S_2$ .
- $SL_{11}$  Now the second slot of  $SL_{00}$  transmits. This results in a collision between  $S_8$  and  $S_{10}$  in the first slot and no transmission in the second.
- $SL_{22}$   $S_8$  and  $S_{10}$  are divided and transmit separately. This results in two successful transmissions by  $S_8$  and  $S_{10}$ .

At this point, all collisions have been resolved successfully, the system is release for new transmission.

In this example, 10 slots are used to transmit 5 packets [11].

A basic weakness in ALOHA protocol is that it does not take into account the information on the intensity of traffic. By taking account on this information, tree algorithm can produce higher throughput than slotted ALOHA system. The ALOHA algorithm when applied to the Poisson source model, has a maximum throughput of 0.37 packets/slot and is unstable. The tree protocol, as Capetanakis has demonstrated that under similar conditions, is stable, has a maximum average throughput of 0.43 and has respectable delay properties.

## 2.7.2 Optimum dynamic tree protocol

The dynamic protocol optimally chooses the tree that is used to resolve a possible contention.



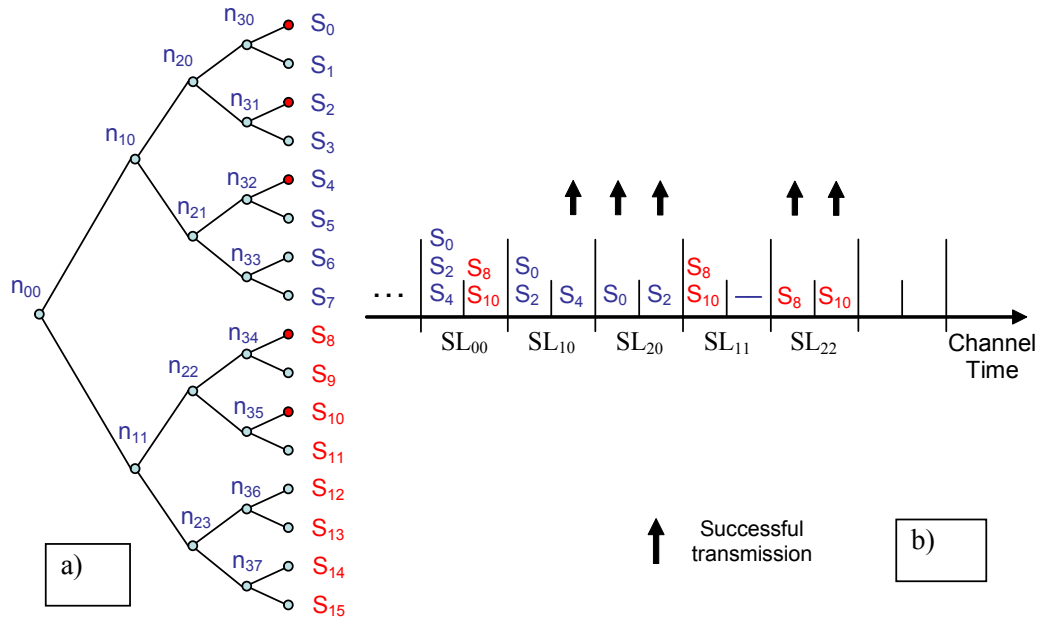

Figure 2.12: An example of binary tree algorithm

The optimum tree is defined to be that which minimizes the average number of slots needed to process the  $2^N$  sources, given that the probability that any one has a packet to transmit is  $q$ . Let  $E\{l \mid q, N, K\}$  be the average number of algorithm steps needed to process  $2^N$  sources when the root node degree is  $2K$ , then the problem is to choose  $K = 1, 2, \dots, N$  so that  $E\{l \mid q, N, K\}$  is minimum.

Now, we will determine  $K^*$ , the optimum  $K$ , as a function of  $q$ . Capetanakis showed that  $K^*$  can be solved by this equation:

$$q^*(N - K) = \begin{cases} 1/\sqrt{2} & \text{for } N - K = 0 \\ 0.38 & N - K = 1 \\ 0.8/2^{N-K} & N - K \geq 2 \end{cases} \quad (2.16)$$

The optimum algorithm is significantly superior for large value of  $q$ , suggesting that the optimum algorithm should be use in heavy traffic.

For  $K = N$  the tree is a single node with  $2^N$  branches. This is the conventional TDMA protocol, in which each user is sequentially allocated every  $2^N$  slot. Performance of optimum tree algorithm in Fig. 2.13 shows that this protocol can vary from random access protocol in light traffic to TDMA in heavy traffic [12].

It is shown that the tree protocol is a generalization of TDMA and that an optimum dynamic tree adaptively changes from an essentially random access protocol in light traffic to TDMA in heavy traffic. When the probability that a user has a packet to transmit,  $q$ , is greater than  $1/\sqrt{2}$  then TDMA and the optimum tree protocol are the same. If, on the other hand,  $q < 1/\sqrt{2}$ , then the optimum tree protocol is more efficient than TDMA [12].

The tree algorithm may be used to access the satellite directly in a direct access system or to access the reservation channel in a reservation access system.

## 2.8 WLAN protocol

In recent years, much interest has been involved in the design of Wireless Local Area Networks (WLAN) [5], [6], [7]. Study group 802.11 is in charge of producing standard for WLAN. Detailed medium access control (MAC) and physical layer (PHY) specifications for WLANs are standardized in [4]. IEEE 802.11 medium access control (MAC) is gaining widespread popularity as layer-2 protocol for WLAN [8].

### 2.8.1 IEEE 802.11 General Architecture

The IEEE 802.11 is a standard constituted by a PHY layer and a MAC layer. Over this layer, the standard foresees interfacing with the standard data LLC layer IEEE

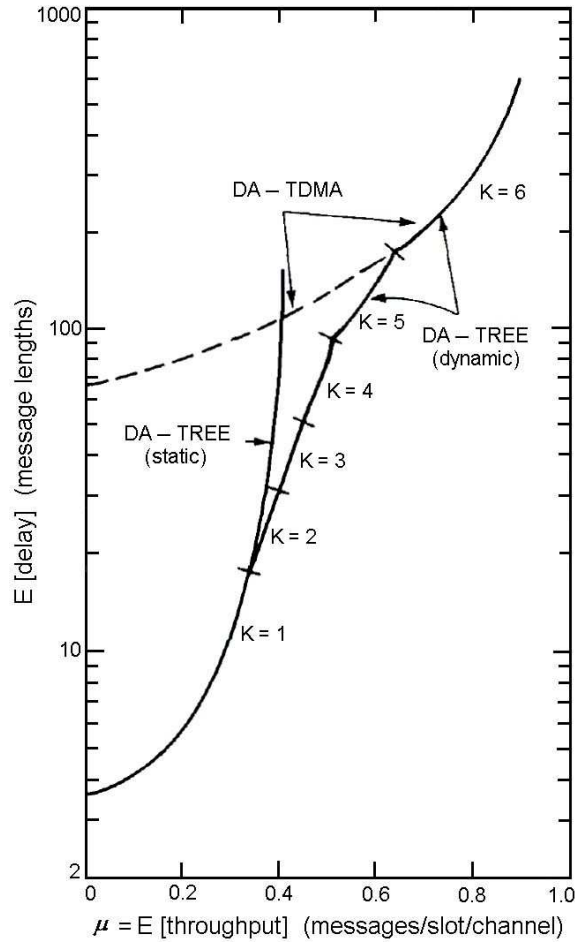

Figure 2.13: Performance of tree algorithm [11]

802.2. The protocol architecture is depicted in Fig. 2.14 where the physical layer (1997) is chosen among three possibilities:

- *Frequency hopping* (FH) spread spectrum;
- *Direct sequence* (DS) spread spectrum;
- *Infrared* (IR).

In 1999, two further physical layers based on radio technology were developed:

- 802.11a : Orthogonal Frequency Division Multiplexing (OFDM) PHY;
- 802.11b : High-rate Direct Sequence (HR/DS or HR/DSSS) PHY; [9]

In the 802.11 MAC protocol, the fundamental mechanism to access the medium is called distributed coordination function (DCF). This is a random access scheme, based on the carrier sense multiple access with collision avoidance (CSMA/CA) protocol. Retransmission of collided packets is managed according to binary exponential backoff rules. The standard also defines an optional point coordination function (PCF) for QoS guarantee services [5]. In this thesis we only consider the DCF scheme. WLAN uses simplex transmission – a station can not transmit and receive data at the same time.

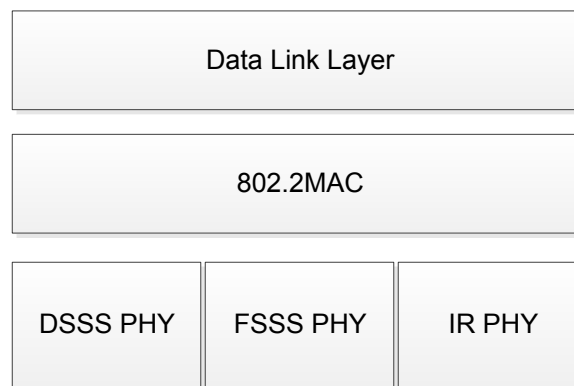

Figure 2.14: Protocol stack [10]

## 2.8.2 Distributed coordination function

DCF describes two techniques for packet transmission: basic mechanism and RTS/CTS mechanism.

*Basic mechanism:* The default scheme is a two-way handshaking technique called basic access mechanism. In this mechanism, a data packet will be added header and transmitted. The destination after successfully received the data packet will transmit back an acknowledgement (ACK) packet to inform the transmitter. Explicit transmission of an ACK is needed because in the wireless environment a transmitter

cannot listen to its own transmission to determine if a packet is successfully received or not.

*RTS/CTS mechanism:* In addition to the basic access, an optional four way handshaking technique, known as request-to-send/clear-to-send (RTS/CTS) mechanism has been standardized. Before transmitting a packet, a station operating in RTS/CTS mode reserves the channel by sending a special Request-To-Send short frame. The destination station acknowledges the receipt of an RTS frame by sending back a Clear-To-Send frame, after which normal packet transmission and ACK response follows. Since collision may occur only on the RTS frame, and it is detected by the lack of CTS response, the RTS/CTS mechanism allows to increase the system performance by reducing the duration of a collision when long messages are transmitted. As an important side effect, the RTS/CTS scheme designed in the 802.11 protocol is suited to avoid Hidden Terminals problem, which occurs when pairs of mobile stations result to be unable to hear each other. In wireless environment, hidden terminals can cause serious trouble and degrade performance of the system. Because of that, the additional RTS/CTS frames will help to produce reliable communication.

RTS/CTS frames are shorter than other frames, so that the mechanism reduces the overhead of collision [10]. Therefore one disadvantage of RTS/CTS is that, when one wants to transmit short packets, RTS/CTS will add inefficient overhead for the transmission and in this case it will reduce the performance of the system.

This section briefly summarizes the DCF as standardized by the 802.11 protocol:

1. A station with a new packet to transmit will sense the channel. If the channel is idle for a distributed interframe space (DIFS) second, the station will transmit its packet.
2. Otherwise, if the channel is sensed busy (either immediately or during the DIFS), the station will continue to sense the channel until the channel idles back for a DIFS. At this point, the station generates a random backoff interval

before transmitting (this is the Collision Avoidance feature of the protocol), to minimize the probability of collision with packets being transmitted by other stations.

For efficiency reasons, DCF employs a discrete-time backoff scale. The time immediately following an idle DIFS is slotted, and a station is allowed to transmit only at the beginning of each slot time. The slot time size depends on the physical layer Direct Sequence Spread Spectrum, Infra Red, Frequency Hopping and being specified in standard.

DCF adopts an exponential backoff scheme. At each packet transmission, the backoff time is uniformly chosen in the range  $[0, W - 1]$ . The value  $W$  is called contention window, and depends on the number of transmissions failed for the packet. At the first transmission attempt,  $W$  is set equal to a value  $CW_{min}$  called minimum contention window. After each unsuccessful transmission,  $W$  is doubled, up to a maximum value  $CW_{max} = 2^m CW_{min}$ .

The backoff time counter is decremented as long as the channel is sensed idle at each slot, stopped when a transmission is detected on the channel, and reactivated when the channel is sensed idle again for more than a DIFS. The station transmits when the backoff time reaches zero. Fig. 2.15 illustrates this operation. Two stations  $A$  and  $B$  share the same wireless channel. At the end of the packet transmission, station  $B$  waits for a DIFS and then chooses a backoff time equal to 8, before transmitting the next packet. We assume that the first packet of station  $A$  arrives at the time indicated with an arrow in the figure. After a DIFS, the packet is transmitted. The transmission of packet  $A$  occurs in the middle of the Slot Time corresponding to a backoff value, for station  $B$ , equal to 5. As a consequence of the channel sensed busy, the backoff time is frozen to its value 5, and the backoff counter decrements again only when the channel is sensed idle for a DIFS.

Since the CSMA/CA does not rely on the capability of the stations to detect a collision by hearing their own transmission, an ACK is transmitted by the destination station to signal the successful packet reception. The ACK is immediately transmitted at the end of the packet, after a period of time called short interframe space (SIFS). As the SIFS (plus the propagation delay) is shorter than a DIFS, no other station is able to detect the channel idle for a DIFS until the end of the ACK. If the transmitting station does not receive the ACK within a specified ACK\_Timeout, or it detects the transmission of a different packet on the channel, it reschedules the packet transmission according to the given backoff rules.

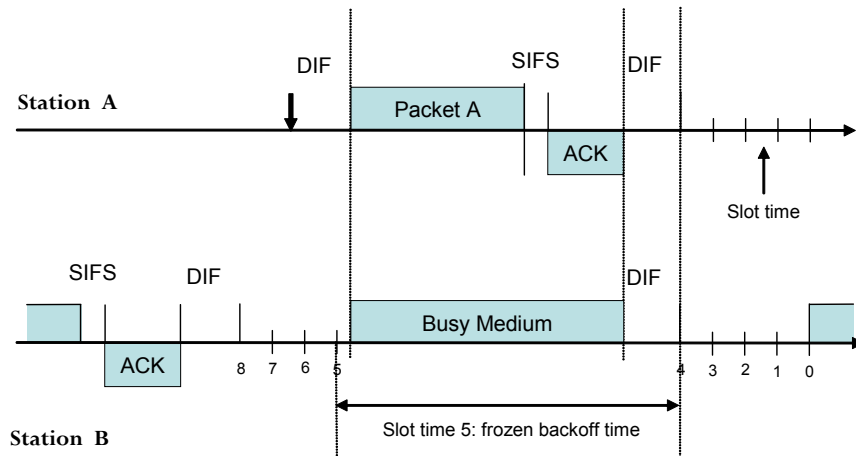

Figure 2.15: Example of basic access mechanism

In RTS/CTS mechanism if station *A* wants to transmit a packet, waits until the channel is sensed idle for a DIFS, follows the backoff rules explained above, and then transmits a short request to send (RTS). When the receiving station *B* detects an RTS frame, it sends back a clear to send (CTS) frame after a SIFS. After receiving CTS correctly, station *A* transmits its packet.

The frames RTS and CTS carry the information of the length of the packet to be transmitted. This information can be read by any listening station, which is then able to update a network allocation vector (NAV) containing the information of the

period of time in which the channel will remain busy. Therefore, when a station is hidden from either the transmitting or the receiving station, by detecting just one frame among the RTS and CTS frames, it can suitably delay further transmission, and thus avoid collision. This process is shown in Fig. 2.16

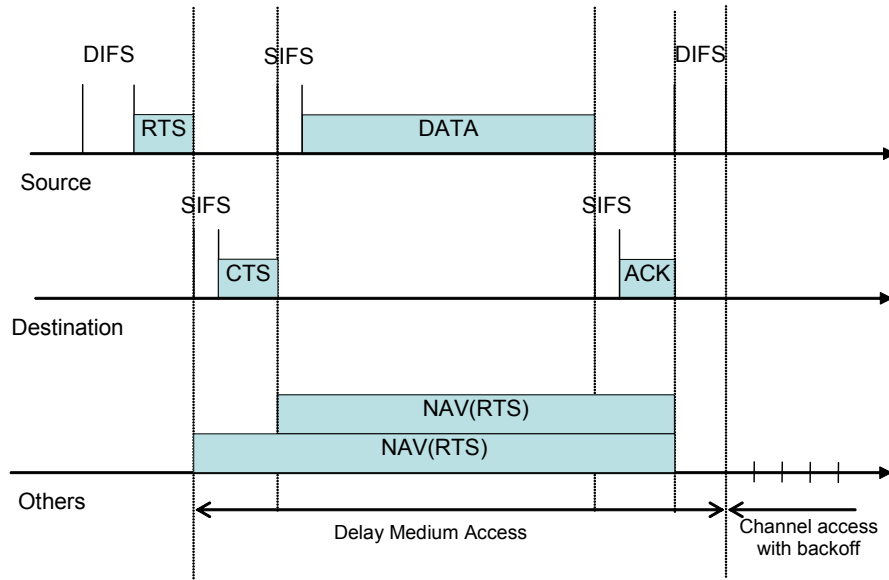

Figure 2.16: RTS/CTS access mechanism

The RTS/CTS mechanism is very effective in terms of system performance, especially when large packets are considered, as it reduces the length of the frames involved in the contention process. In fact, in the assumption of perfect channel sensing by every station, collision may occur only when two (or more) packets are transmitted within the same slot time. If both transmitting stations employ the RTS/CTS mechanism, collision occurs only on the RTS frames and we lose only small channel resource. That is the main reason for RTS/CTS mechanism to get a better performance than basic mechanism.

By adding two small control frames, we can secure the channel for transmission. This RTS/CTS mechanism is widely used for existing commercial WLAN products.



## 2.9 FAWAC protocol

TDMA scheme is well known and widely used for satellite communication. TDMA works well under high traffic but it suffer long delay when the traffic is low. FAWAC (Fixed Assignment based Window Access with Capture) [16] protocol was designed for such situation.

FAWAC was a development of FAWA (Fixed Assignment based Window Access) scheme [17]. In FAWA scheme, the assignment is the same as TDMA scheme. The authors introduce a new concept: control window ( $W$ ). The algorithm is:

1. If a new packet is generated inside the window, this packet will have to wait until its assigned slot to transmit.
2. Else, that packet will be transmitted at next time slot.
3. Retransmission is always in assigned time slot.

With this algorithm we have a hybrid TDMA-ALOHA protocol. If the window size is big, then the FAWA scheme behaves like the TDMA scheme. And, if the window size is small, then the FAWA scheme acts like the slotted ALOHA scheme. We can control the window size to achieve high performance in FAWA scheme.

In FAWAC scheme, we employ the capture effect to get a better performance. Algorithm of FAWAC protocol is described below:

- If a packet is generated outside the window, then the station transmits a packet in next time slot with low power level.
- If the station generates a packet inside the window, then the station should wait until the assigned slot for that station (in this example, slot No10) and send the packet in the assigned slot with high power level in order to exploit the capture effect. However the packet sent with high power.

- In FAWAC scheme, each station should retransmit collided packets in the assigned slot. In this way, the assigned transmission has always priority over immediate transmissions, and there is no chance of collision between the collided packets.

An example of the channel configuration of FAWAC scheme is shown in Fig. 2.17. In Fig. 2.17, we illustrate the example of FAWAC scheme with station No.10, window size  $W$  is 4.

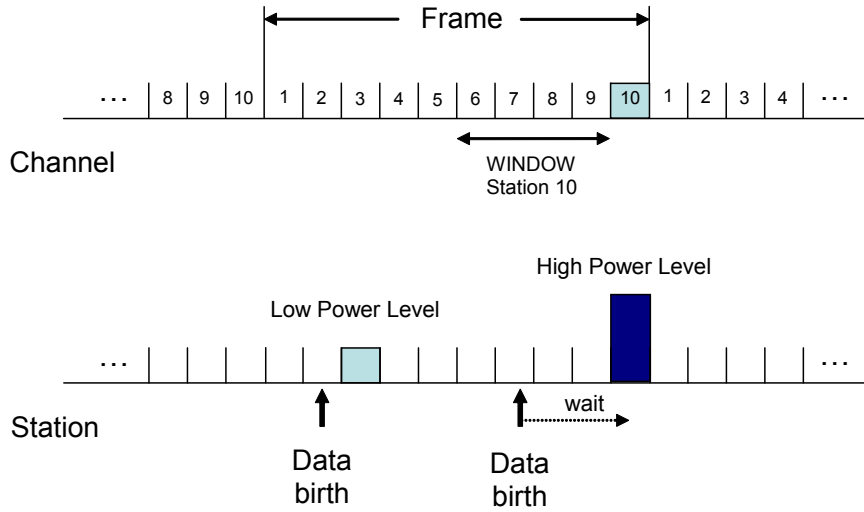

Figure 2.17: FAWAC protocol

The window is established before the assigned slot, therefore the slot 6, 7, 8 and 9 are the widow for the station No.10 in this case. The concept of the window is the threshold for waiting time to send a packet in each station, therefore, the smaller the window value is, the shorter the waiting time of the station. The parameter  $C$  here is the threshold for capture effect. The high power level packet can only get through the channel if no more than  $C$  low power packets exist in the same slot.

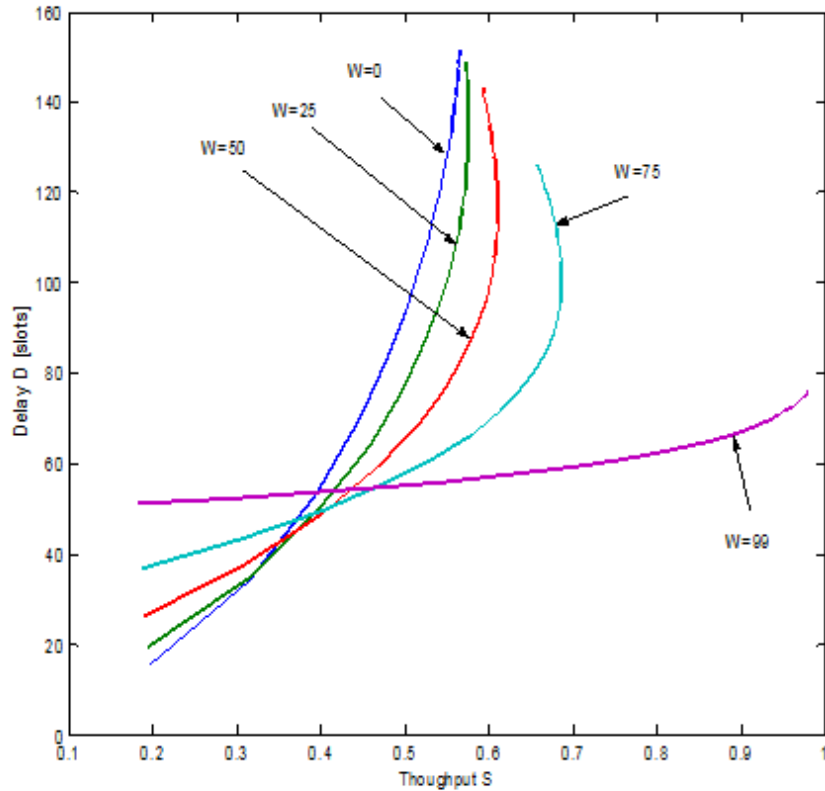

Figure 2.18: FAWAC performance ( $N = 100$ ;  $W = 0, 25, 50, 75, 99$ ;  $c = 0$ )

### 2.9.1 Performance of FAWAC under different conditions

From this figure we can see that  $W = 0$  the system will become to slotted ALOHA system. When  $W = 99$  the system is equivalent to TDMA system. With this algorithm, we can make a smooth transition in the behavior of the system according to the traffic pattern, from ALOHA when the traffic is low to TDMA when the traffic is high.

The performance of the system will be dramatically improved when we employ capture effect. These improvements are reflected in fig. 2.18, 2.19.

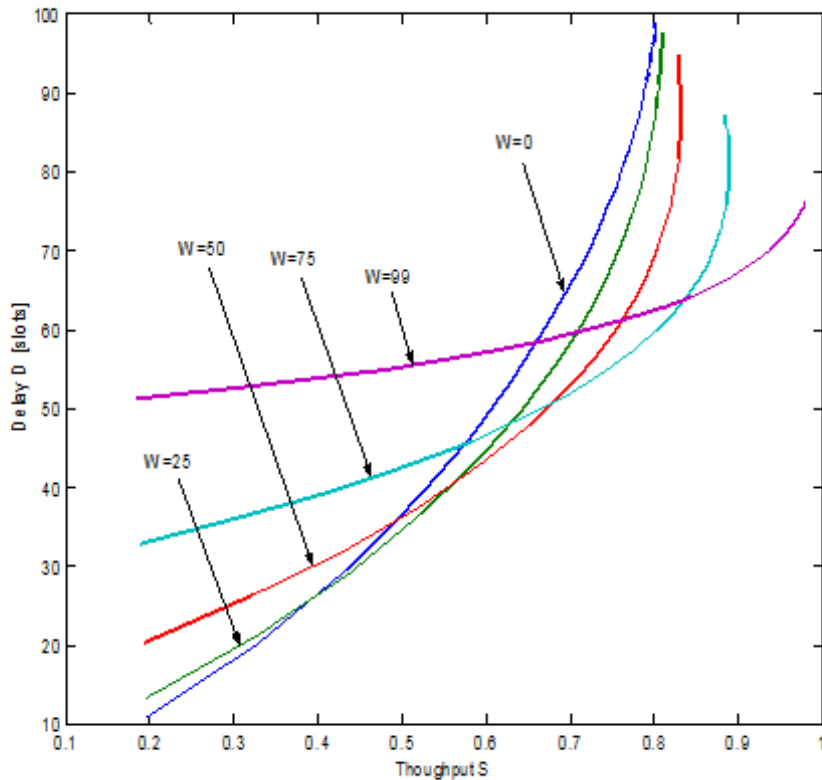

Figure 2.19: FAWAC performance ( $N = 100$ ;  $W = 0, 25, 50, 75, 99$ ;  $c = 1$ )

## 2.10 ALOHA with capture effect

This algorithm is an extension of conventional slotted ALOHA algorithm to employ capture effect. This approach was studied widely [18], [3], ... Suppose that we have  $L$  signal levels that the station can choose for packet transmission. It is generally accepted that capture effect can increase performance of the system. Here we only consider perfect capture effect.

- If two or more packets at the same power level are transmitted at the same time then collision occurred.

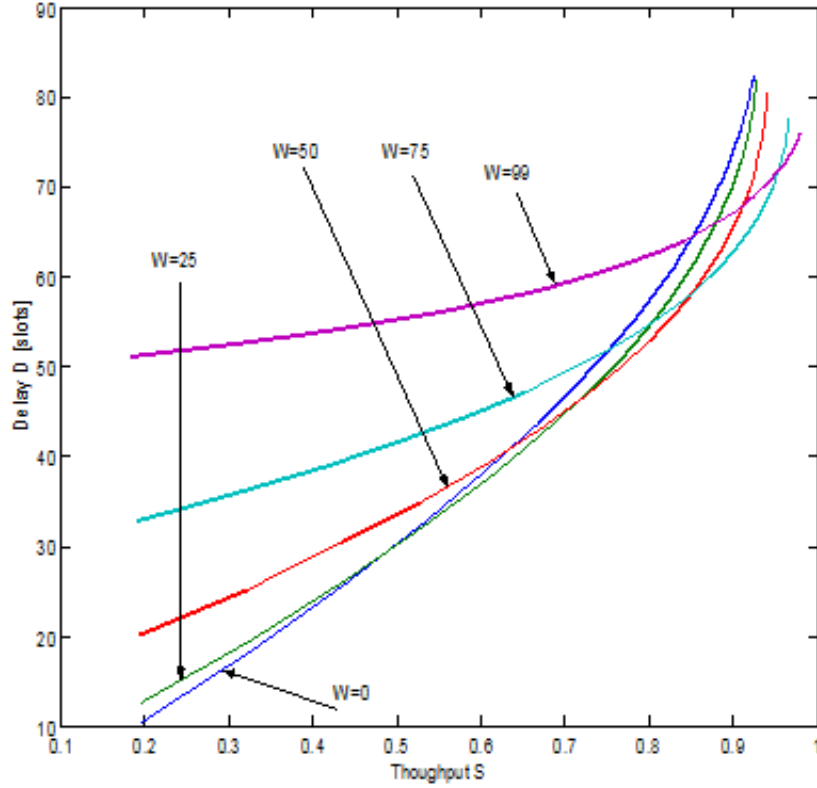

Figure 2.20: FAWAC performance ( $N = 100$ ;  $W = 0, 25, 50, 75, 99$ ;  $c = 2$ )

- If there are two or more packets are transmitted at the same time but there is one packet that has the highest power will *capture* all other packets and this packet will be received successfully.

A packet to be transmitted will first randomly choose one power level out of  $L$  different signal levels, then it will be transmitted as in case of slotted ALOHA. If collision occurs then that packet will be retransmitted with probability  $r$ .

Shimamoto, ect [18] calculated the throughput and delay of the system are:

$$S = \frac{G(1 - e^{-G})}{L(1 - e^{-G/L})} e^{-G/L} \quad (2.17)$$

$$D = 1 + \left\{ \frac{L(e^{-G/L} - 1)}{1 - e^{-G}} \right\} \frac{1}{r} \quad (2.18)$$

where  $G$  is the offer load.

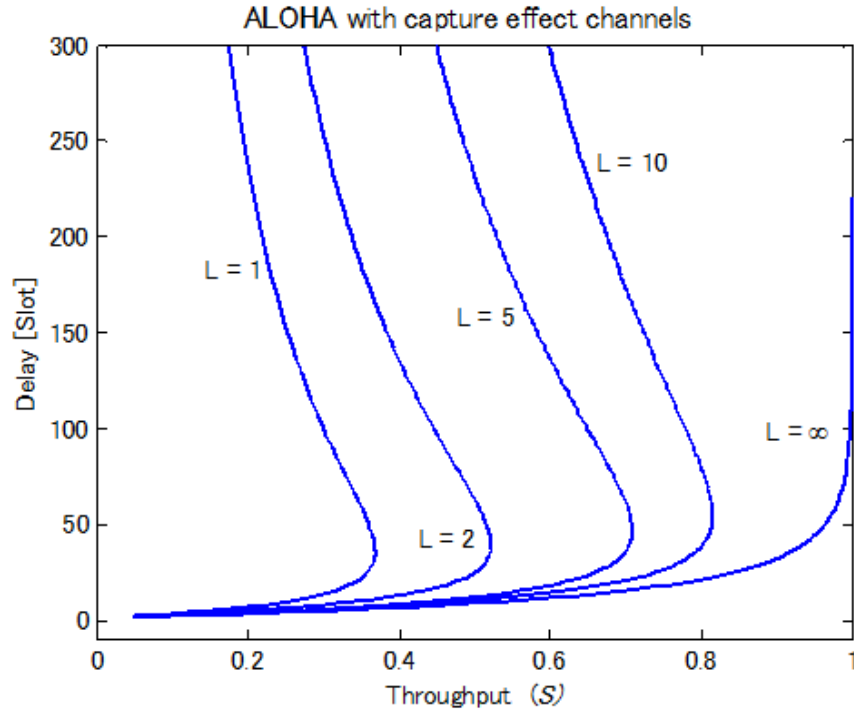

Figure 2.21: Delay-Throughput characteristics of randomly selected power level based multiple access scheme ( $N = 100$ ;  $r = 0.05$ ;  $L = 1, 2, 5, 10, \text{inf}$ )

From Fig. 2.21 we can see that  $L = 1$  is conventional slotted ALOHA system. Performance of the system increases according to the increase of  $L$ . Like the conventional slotted ALOHA system, this system also shows unstable when  $G$  reaches to a certain value.

## 2.11 Sequentially assigned power level based multiple access scheme

Another protocol that also employ capture effect is Sequentially assigned power level based multiple access protocol [18]. This protocol is an extended version of TDMA protocol. Suppose we have  $N$  stations and  $L$  power levels. Channel will be separate into time slot like in TDMA. The difference here is each time slot will have (at most)  $L$

contention station. Fig. 2.22 is an example of this arrangement. In this arrangement, each frame will have  $\text{ceil}(N/L)$  time slots. The power level given for each station will be in cyclic way. Fig. 2.22 is an intuitive example in case of  $N = 16$  and  $L = 4$ .  $P_i$  stands for packet of station  $i$ . From the Fig. 2.22 we can see that at frame 0, station 1 will be given power level 1. At the following frame, the power level will be increase. That assignment is natural because if a transmission fails, next retransmission it will have higher priority to get through the channel by being given higher power level.

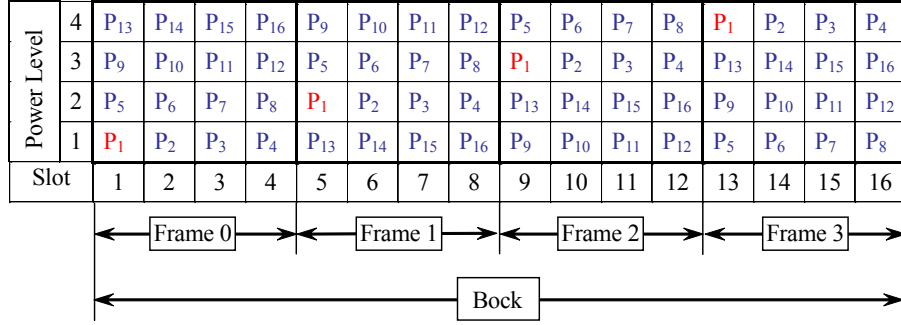

Figure 2.22: Channel arrangement of sequentially assigned power level based multiple access protocol

As a result, we can avoid collision among same power level packets and have a successful transmission in every slot.

The throughput of this scheme is:

$$S = \sum_{i=1}^L \left\{ [1 - e^{-g} + e^{-g} P_c(l - 1)] \times \prod_{i=l+1}^L (1 - P_c(i - 1)) e^{-g} \right\} \quad (2.19)$$

where:

- $G$  is total offer load
- $g = \frac{G}{L}$  is traffic intensity and

- $P_c(l)$  is the probability of a packet unsuccessfully transmitted at level  $l$  due to capture effect.

Performance of the system is illustrated in Fig. 2.23 and 2.24.

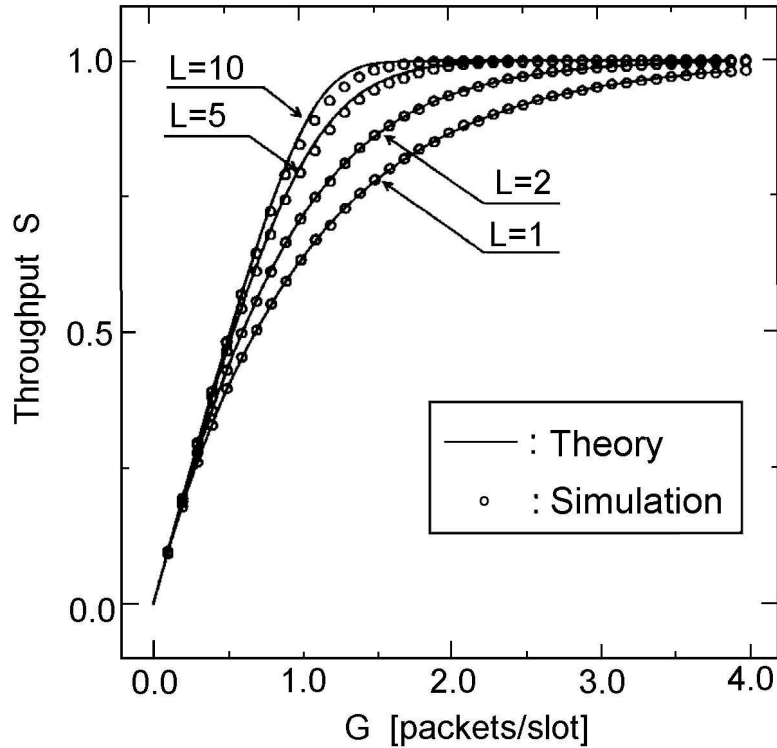

Figure 2.23: Throughput of sequentially assigned power level based multiple access protocol [18]

In this scheme, the probability of a successful transmission of a lower power packet under heavy traffic is considerably reduced since these packets may be captured by the higher powered ones. So, the retransmission of the packet is needed until the power level of the packet is high enough not to be captured. On the other hand, the probability of a successful transmission of a lower power packet is high under light traffic.

The advantage of this access scheme is that it can reduce collision among same-power-level packets, so as to have a successful packet in every slot. When the system has lower traffic, a station is able to transmit a packet successfully with lower power.



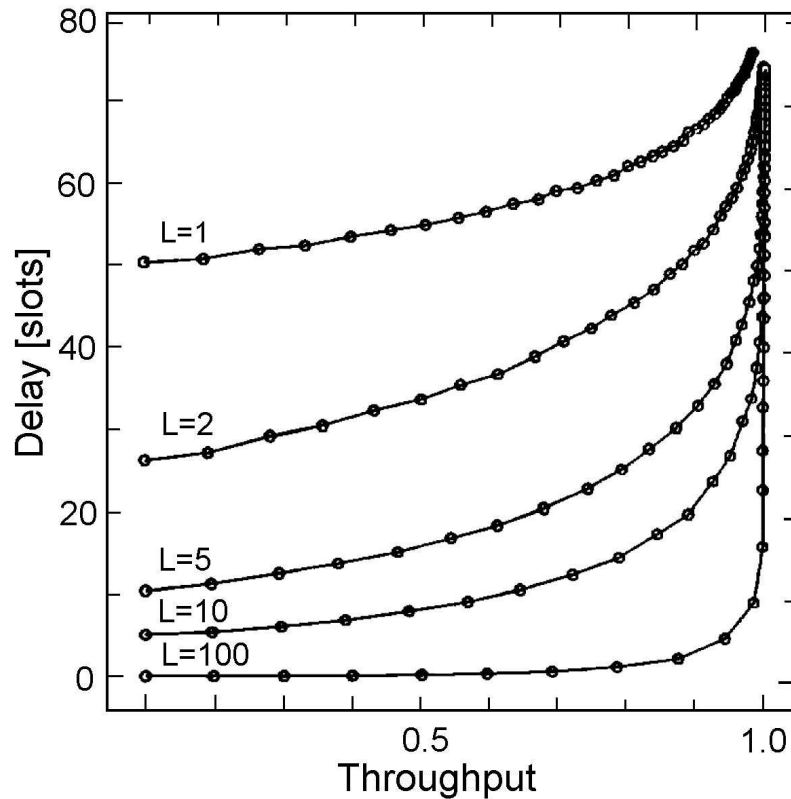

Figure 2.24: Throughput-Delay characteristic of sequentially assigned power level based multiple access protocol [18]

When the system's traffic is high, a station has to retransmit the packet several times until it is assigned high enough power level to get through channel by capture effect. One can easily see that this scheme has the performance of fixed assigned access scheme in high traffic condition, and has lower delay at lower traffic region.

## 2.12 Conclusion

In this chapter we have reviewed relevant MAC protocols which related to our study. The reviewed MAC protocols are by no mean completed. The protocols are also not list according to chronological order. They are arranged following the research topics and further development.

During the course of studying the above mentioned protocols, we paid special attention to the analytical parts. The analytical solution play a key role in any protocol research. Our achievements based firmly on those analysis.

# Bibliography

- [1] R. G. Gallager, A perspective on multiple access channels, *IEEE Trans. On Information Theory*, p.124-142, IT-31, 1985.
- [2] J. G. Proakis, Digital communications, 4th edition, McGraw-Hill, 2001.
- [3] C. C. Lee, Random Signal Levels for channel access in packet broadcast networks, *IEEE Journal on Selected areas in communications*, vol. SAC-5, no. 6, Jul. 1987
- [4] IEEE Standard for Wireless LAN Medium Access Control (MAC) and Physical Layer (PHY) Specifications, Nov. 1997. P802.11.
- [5] G. Bianchi, Performance analysis of the IEEE 802.11 distributed coordination function, *IEEE Journal on Selected areas in communications*, vol. 18, no. 3, pp. 535-547, Mar. 2000.
- [6] E. Ziouva, T. Antonakopoulos, CSMA/CA performance under high traffic conditions: throughput and delay analysis, vol. 25, no. 3, p. 313-321, *Computer communications*, 2002.
- [7] B. P. Crow, I. Widjaja, J. G. Kim, P. T. Sakai, IEEE 802.11 Wireless Local Area Networks, *IEEE Communications Magazine*, vol. 35, no.9, p. 116-126, Sep. 1997.
- [8] O. Tickoo, B. Sikdar, On the impact of IEEE 802.11 MAC on traffic characteristics, *IEEE Journal on Selected areas in communications*, vol. 21, no.2, pp. 189-203, Feb. 2003.

- [9] M. S. Gast, 802.11 wireless networks the: definitive guide, OReilly, 2002
- [10] R. Prasad, L. Munoz, WLANs and WPANs towards 4G Wireless, Artech House, Mar. 2003
- [11] J. Capetanaki, Tree algorithms for packet broadcast channels, *IEEE Transaction on Information Theory*, vol. 25, no. 5, pp. 505-515, Sep. 1979.
- [12] J. Capetanaki, Generalized TDMA: the multi-accessing tree protocol, *IEEE Transaction on Information Theory*, vol. 25, no. 5, pp. 1476-1484 , Sep. 1979.
- [13] B. S. Tsybakov, A. V. Mikhailov, Free synchronous packet access in a broadcast channel with feedback, *Probl. Pered. Inform.* Vol. 14, 1978.
- [14] A. J. E. M. Janssen, M. J. M. de Jong, Analysis of contention tree algorithms, *IEEE Transaction on Information theory*, vol. 46, no. 6, pp. 2163-2172, Sep. 2000.
- [15] J. D. Spragins, J. L. Hammond, K. Pawlikowski, *Telecommunications Protocols and Design*, Addison-Wesley, 1992.
- [16] S. Shimamoto, H. Kudo, Y. Onozato, Fixed assignment based window access with capture (FAWAC) for personal satellite communications, *GLOBECOM 1994 Proceeding*.
- [17] T. Inada, S. Shimamoto, Y. Onozato, Combined ALOHA/TDMA access scheme with TDMA windows control, *IEICE B-II*, vol. J-73, No.8, 1980.
- [18] S. Shimamoto, Y. Onozato, Y. Teshigawara, Performance evaluation of power level division multiple access (PDMA) scheme, *ICC'92*
- [19] N. Abramson, The throughput of packet broadcasting channels, *IEEE Transaction on Communications* vol. COM-25, no. 1, Jan. 1977.

- [20] L. Kleinrock, F. A. Tobagi, Packet switching in radio channels: Part I Carrier sense multiple-access models and their throughput-delay characteristics, *IEEE Transaction on Communications*, vol. COM23, no. 12, Dec. 1975.
- [21] S. Verdu, *Multiuser Detection*, Cambridge University Press 1998

## Chapter 3

# Continuous Contention-Assisted Transmission MAC Protocol for Wireless Ad-Hoc Network

In this chapter we introduce a new MAC protocol called Continuous Contention-Assisted Transmission (CAT) for wireless Ad-hoc network. This proposed protocol is based on Carrier sense multiple access with collision avoidance (CSMA/CA). We have modified the ACK packet and re-designed mobile stations behavior so as stations could continuously transmit data without contention as much as possible. The proposed algorithm manages to keep collision in the network as low as possible by allowing wireless stations to form a sequence of transmission among stations that have data to send. Analytical solution is developed using Markov chain tool to predict the network performance and results are compared with numerical simulations. The results show that the analytical model is quite accurate in predicting network throughput.

## 3.1 Introduction

The idea of using a token for data transmission has been applied successfully in wire network. Token bus was standardized by IEEE standard 802.4. Its coordinated medium access, the token bus concept, was believed to be superior to 802.3s contention-based scheme [13]. In a wireless network, the idea of applying token to the MAC protocol is not very popular due to token handling in wireless environment, in general, is very difficult. In specific cases, it is quite possible to employ the token concept to wireless network to boost performance.

Recently a wireless token ring protocol (WTRP) [12] has been proposed to eliminate the backoff inefficiencies and the collision problems in ring topology. This WTRP protocol is good in some respects but rather complicated to implement. Stations have to be structured in a well defined ring topology and transmission will be scheduled for each node. This structured topology can alleviate collision problem but at the same time wireless network loses its flexibility.

The analysis of 802.11 DCF under saturated condition by using Markov chain has been successfully carried out by Bianchi in his legacy paper [1]. This model has been extended to model WLAN under unsaturated condition in [4]. In this paper, we apply this idea to analyze our proposal. The rest of this paper is organized as follows: Section II proposes a new protocol gives an example. Section III develops analytical model to estimate the total network throughput. Section IV provides simulation results. Conclusions are drawn in Section V.

## 3.2 Continuous Assisted Transmission Protocol

This proposed protocol is based on the following assumption: all stations have some information of others stations in their communication ranges. In order for other stations to actively involve in the cooperation process, ACK packet is redesigned by

adding a new field with the size of 6 octets. This newly added field is enough to contain another address.

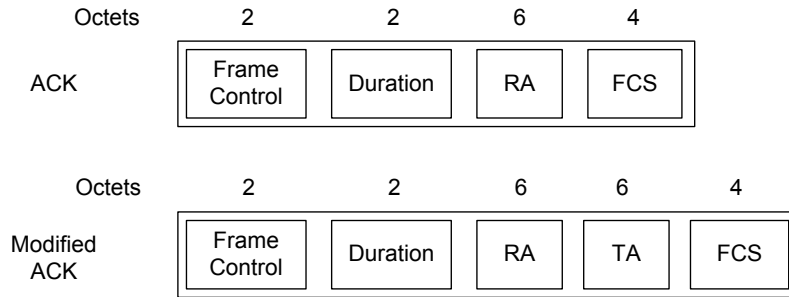

Figure 3.1: Structure of modified ACK

We should point out here that the modified ACK frame may have the same configuration of RTS frame. Therefore, a method should be developed in order to differentiate those frames, such as a sequence of bits is added as an identifier to those frames. In this paper, we simply assume that stations could distinguish modified ACK and RTS frames.

The algorithm is as follow: If station **A** has data to send and it successfully accesses channel, it will transmit this data to station **B** in RTS/CTS mechanism. After successfully decoding this data, station **B** will randomly choose a station, say station **C**. Station **C**'s address is added to the modified ACK packet and then sent back.

If station **C** has data to send, it will transmit after SIFS [s] following BASIC scheme if there is no hidden terminal problem or RTS/CTS scheme if hidden terminal problem exists. Otherwise, channel will be left IDLE during DIFS [s]. After DIFS [s] period, channel will be released for other stations to access following RTS/CTS scheme.

By re-designing ACK frame, network could have more information to combat collision transmission in high traffic period efficiently. When traffic is very low, it works just like the original 802.11 DCF protocol with negligible deficiency because of



longer ACK frame. When traffic becomes higher, this added information is clearly paid off. Fig. 3.2 provides an example of transmission sequence of this protocol:

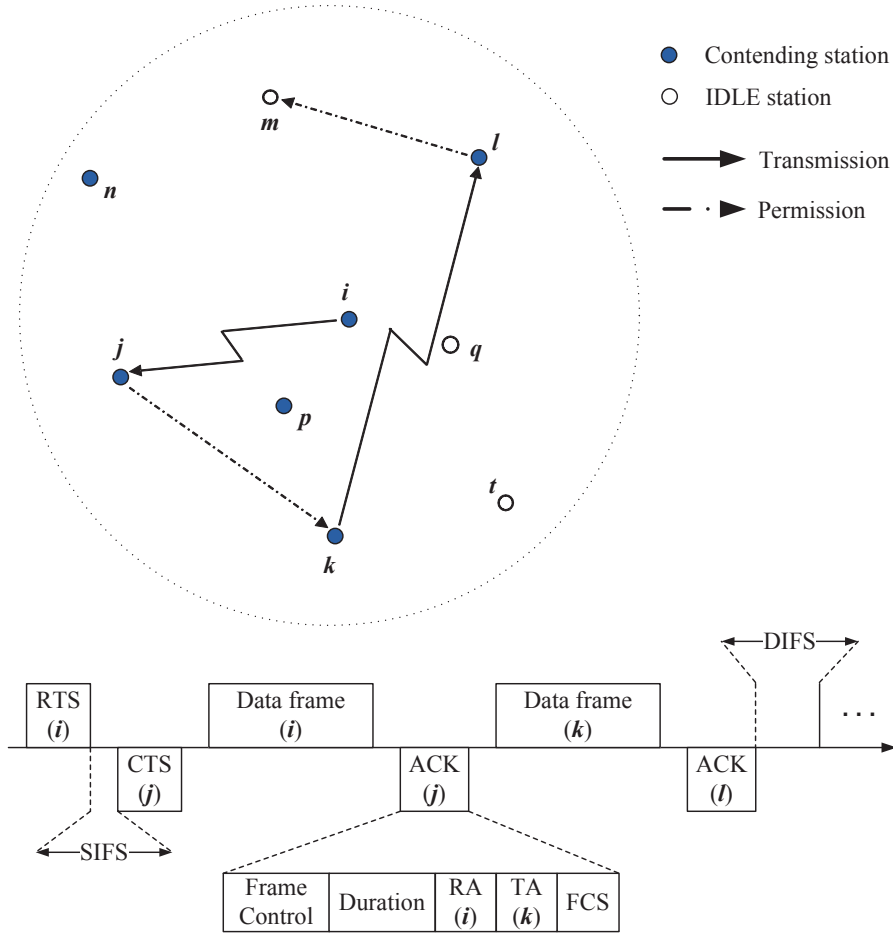

Figure 3.2: Graphical presentation of continuous transmission

1. Station  $i$  transmits its data packets to station  $j$  in RTS/CTS scheme.
2. The data frame successfully receives by  $j$ . Supposedly station  $j$  knows that stations  $\{k, n, p, q\}$  are in its transmission range. It then randomly chooses a candidate from this set for the next transmission:  $RAND(\{k, n, p, q\}) \rightarrow k$ . Station  $j$  then compiles the ACK frame with station  $k$ 's address is put in the next transmission (TA) field. This ACK frame is sent back to station  $i$ .
3. After receiving this permission SIFS [s], station  $k$  transmits its data packet to station  $l$  in BASIC scheme. Because the channel is only inactive in SIFS [s],

other stations will remain silence and update their Network Allocation Vector (NAV)

4. After successfully decode the data frame from station  $k$ , station  $l$  will allow station  $m$ , in its transmission range, to transmit. As station  $m$  has no data packet to send it will remain in its IDLE state. After channel is left inactive during DIFS [s], other stations can access it following RTS/CTS scheme.

### 3.3 Analytical model

The Markov chain for one station is depicted in Fig. 3.3 We encode those Markov states with the following symbols in Table 3.1

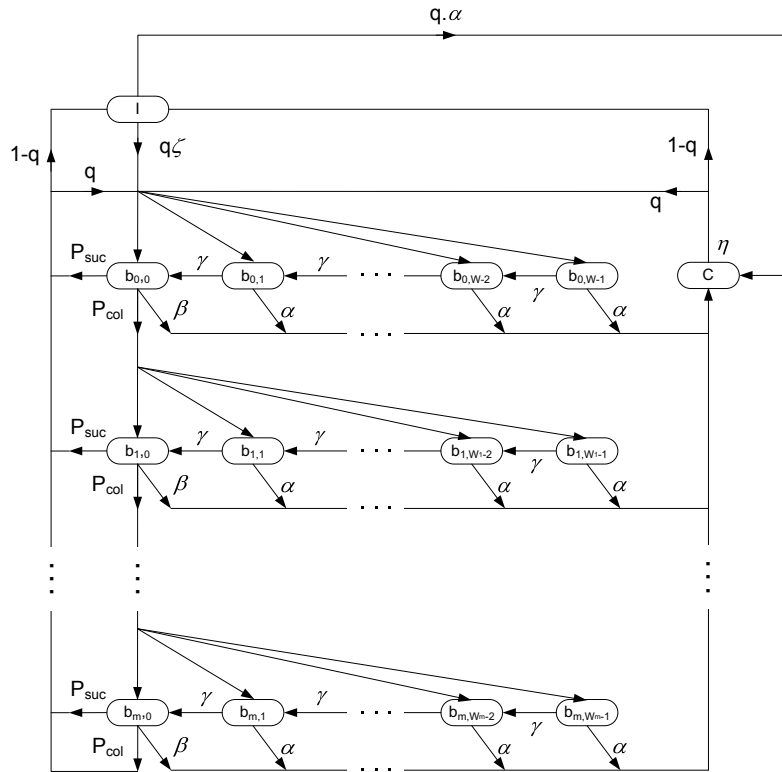

Figure 3.3: Markov model of CAT

Table 3.1: Markov states and transition probabilities

---

$b_{i,k}$	back off stage.
$b_{i,0}$	a station starts its own transmission
$C$	a station transmits without contention
$I$	a station will go to this state after successfully transmitting its own data, and then there is no other waiting packet in its queue

---

$q$	Probability that a station has data in the queue
$\alpha, \beta$	Probability that a station is giving permission to transmit without contention
$\gamma$	Probability that a station counts down its back-off counter
$\eta$	Probability that a station leaves $C$ state
$q\zeta$	Probability that station leaves $I$ state when a new packet arrive
$P_{suc}$	Probability that it successfully transmitted data in contention
$P_{col}$	Probability that the transmission is unsuccessful due to collision

---

### 3.3.1 Basic equations

The transition probabilities of Markov Process of Fig. 3.3 are as follow:

$$\begin{aligned}
P_{i,k|i,k+1} &= \gamma \\
P_{0,k|i,0} &= q.P_{suc}/W_0 \\
P_{0,k|m,0} &= q.(P_{suc} + P_{col})/W_0 \\
P_{0,k|C} &= q.\eta/W_0 \\
P_{i,k|i-1,0} &= P_{col}/W_i \\
P_{I|i,0} &= (1 - q).P_{suc} \\
P_{I|m,0} &= (1 - q).(P_{suc} + P_{col}) \\
P_{0,k|I} &= q.\zeta/W_0 \\
P_{C|I} &= q.\alpha \\
P_{I|C} &= (1 - q).\eta
\end{aligned} \tag{3.1}$$

The first equation account for the fact that station can only decrease its back-off counter when the channel is idle for a whole slot time. The second and third equations explain the events happened when a station successfully transmits its packet or the packet is dropped and a new packet arrives. The packet can be successfully transmitted with probability  $P_{suc}$  or collides with other packets with probability  $P_{col}$ . Other equations are self-contained. With those transition probabilities, we could write the equation for the whole stationary distribution of Markov chain. If we set:

$$A_0 = \frac{\beta + P_{suc} + P_{col}}{1 + \frac{\gamma}{\alpha} \left\{ 1 - \left( \frac{\gamma}{\alpha + \gamma} \right)^{W-1} \right\}} \tag{3.2}$$

then

$$b_{0,k} = \frac{1}{\alpha} \left\{ 1 - \left( \frac{\gamma}{\alpha + \gamma} \right)^{W-k} \right\} A_0 b_{0,0} \quad (3.3)$$

$0 < k < W$

Equation (3.3) shows that we could relate of other states  $b_{0,k}$  through  $b_{0,0}$ . The same calculations give at the following relationship:

$$b_{i,k} = \frac{1}{\alpha} \left\{ 1 - \left( \frac{\gamma}{\alpha + \gamma} \right)^{W_i-k} \right\} A_i b_{i,0} \quad (3.4)$$

with

$$A_i = \frac{\beta + P_{suc} + P_{col}}{1 + \frac{\gamma}{\alpha} \left\{ 1 - \left( \frac{\gamma}{\alpha + \gamma} \right)^{W_i-1} \right\}} \quad (3.5)$$

$$\begin{aligned} b_{i,0} &= \frac{1}{A_i} \frac{P_{col}}{W_i} b_{i-1,0} = B_i b_{i-1,0} \\ &= \dots = \left( \prod_{l=0}^i B_l \right) b_{0,0} \end{aligned} \quad (3.6)$$

$$B_i = \begin{cases} 1 & i = 0 \\ \frac{1}{A_i} \frac{P_{col}}{W_i} & 1 \leq i \leq m \end{cases} \quad (3.7)$$

We would like to verify the protocol in the extreme case to see that if it could shrink back to Daneshgaran's model? This situation means that:

$$\begin{cases} \alpha = 0 \\ \beta = 0 \end{cases}$$

under this condition:  $C = 0$  and after some algebra, we come to:  $A_i = 1/W_i$ , therefore  $B_i = 1$ . This verifies that our model is indeed reduced back to the original Daneshgaran's model.

Set

$$\theta = \sum_{i=0}^m b_{i,0} = \sum_{i=0}^m \left( \prod_{l=0}^i B_l \right) b_{0,0} = \Theta b_{0,0} \quad (3.8)$$

$$\begin{aligned} \varphi &= \sum_{i=0}^m \sum_{k=1}^{W_i-1} b_{i,k} \\ &= \sum_{i=0}^m \sum_{k=1}^{W_i-1} \frac{1}{\alpha} \left\{ 1 - \left( \frac{\gamma}{\alpha + \gamma} \right)^{W_i-k} \right\} A_i b_{i,0} \\ &= \sum_{i=0}^m \frac{1}{\alpha} \left[ (W_i - 1) - \frac{\gamma}{\alpha} \left\{ 1 - \left( \frac{\gamma}{\alpha + \gamma} \right)^{W_i-1} \right\} \right] \times \\ &\quad A_i \left( \prod_{l=0}^i B_l \right) b_{0,0} \\ &= \Phi b_{0,0} \end{aligned} \quad (3.9)$$

The next step is to find the relation between  $I$ ,  $C$  and  $b_{0,0}$  the following equations:

$$\begin{cases} q(\alpha + \zeta)I = (1 - q) [P_{suc}\theta + P_{col}b_{m,0} + \eta C] \\ \eta C = q\alpha I + \beta\theta + \alpha\varphi \end{cases} \quad (3.10)$$

Solving Eq. 3.10 will give us:

$$\begin{aligned} I &= \frac{1 - q}{q(\zeta + q\alpha)} \left[ (P_{suc} + \beta)\Theta + P_{col} \prod_{l=0}^m B_l + \alpha\Phi \right] b_{0,0} \\ &= E b_{0,0} \end{aligned} \quad (3.11)$$

$$\begin{aligned} C &= \frac{1}{\eta} [q\alpha E + \beta\Theta + \alpha\Phi] b_{0,0} \\ &= F b_{0,0} \end{aligned} \quad (3.12)$$

### 3.3.2 Normalized condition

By relations (3.8) - (3.12) we could express all stages of the model through  $b_{0,0}$ .  $b_{0,0}$  then can be obtained by normalized condition:

$$\begin{aligned} \theta + \varphi + I + C &= 1 \\ (\Theta + \Phi + E + F) b_{0,0} &= 1 \\ \longrightarrow b_{0,0} &= \frac{1}{\Theta + \Phi + E + F} \end{aligned} \quad (3.13)$$

Therefore  $b_{0,0}$  is explicitly defined.

### 3.3.3 Key transition probabilities

We can now then express key transition probabilities:

$$\left\{ \begin{array}{l} \alpha = \theta(\varphi + I)^{N-2} + C(\theta + \varphi + I)^{N-2} \\ \beta = C(\theta + \varphi + I)^{N-2} \\ \gamma = (\theta + \varphi + I)^{N-1} \\ \eta = (\theta + \varphi + I)^{N-1} \\ \zeta = (\theta + \varphi + I)^{N-1} - \theta(\varphi + I)^{N-2} + \\ \quad (N - 2)C(\theta + \varphi + I)^{N-2} \\ P_{col} = (\theta + \varphi + I)^{N-1} - (\varphi + I)^{N-1} \\ P_{suc} = (\varphi + I)^{N-1} \\ q = 1 - e^{-\lambda E_s} \end{array} \right. \quad (3.14)$$

We need to provide some explanation to those equation, especially  $\zeta$ . According to the protocol, after successful transmission in  $b_{i,0}$ , the receiving station will give permission to other station in its transmission range. If that station has data in its buffer, then it will proceed the transmission process. This event means that all other stations will maintain their current states. We, however, do not have a proper mean to signal other stations explicitly because the event that next station will transmit or not is in the future. Therefore, we still allow those stations to reduce their back-off counters, but we will block this reduction when there is a success transmission in  $C$  state. Therefore the Markov chain still follows the proposal protocol correctly. Based on this technique, other equations will follow naturally. The parameter  $E_s$  is the average duration of a slot.  $q$  is calculated under the assumption that packet arrival rate follow Poisson distribution.  $E_s$  is derived from idle slot ( $\sigma$ ), success transmission in  $b_{i,0}$  ( $T_{s1}$ ), success transmission in  $C$  ( $T_{s2}$ ) and collision transmission ( $T_c$ ) with



respect to probabilities  $P_{idle}$ ,  $P_{s1}$ ,  $P_{s2}$  and  $P_c$  as in [4]:

$$\begin{cases} P_{idle} &= (I + \varphi)^N \\ P_{s1} &= N \theta (\varphi + I)^{N-1} \\ P_{s2} &= N C (\theta + \varphi + I)^{N-1} \\ P_c &= (\theta + \varphi + I)^N - P_{idle} - P_{s1} \end{cases} \quad (3.15)$$

then

$$E_s = P_{idle} \sigma + P_{s1} T_{s1} + P_{s2} T_{s2} + P_c T_c \quad (3.16)$$

Solving Eq. 3.14-3.16 will provide us the stationary distribution of Markov chain for the given station. Based on that total network throughput will be:

$$S = \frac{(P_{s1} + P_{s2}) L}{E_s} \quad (3.17)$$

### 3.4 Model validations and Simulation result

In this section, we compare our analytical result against Daneshgaran's model. We also validate it with simulation results in our Matlab simulator.

We setup our simulations as follow: mobile stations are placed randomly on a circle with radius  $R = 30\text{m}$ . No mobility and hidden terminal are considered in this simulation. Simulation is carried out 3 times for each setting. Throughput is evaluated by averaging over that 3 samples. Under this experiment setting, stations will transmit packets directly to each other without using routing protocol.

The main comparisons are presented in Fig. 3.4-3.5. We observe that the proposed model agree well simulation outputs. However, there is a small different, especially in the area of  $20 \leq \lambda \leq 40 [pkts/s]$  of Fig. 3.4. We attribute this issue to the approxi-

Table 3.2: Simulation Parameters

Parameter	Value
SIFS	10 $\mu s$
DIFS	50 $\mu s$
Slot Time ( $\sigma$ )	20 $\mu s$
PHY header	192 bits
MAC header	224 bits
ACK	112 bits + PHY header
RTS	160 bits + PHY header
CTS	112 bits + PHY header
$CW_{min}$	31
Maximum backoff stage ( $m$ )	4
Transmission Rate	1 Mbps
Packet Payload	500 Bytes
ACK timeout	314 $\mu s$
Total number of stations	10, 30

mation of  $q$  parameter. The main reason in our opinion is that: the probabilities of new packet arrival sees that the queue is empty are different in  $I$ ,  $b_{i,0}$  and  $C$  states.

The continuous transmission behavior is best explained in Fig. 3.6-3.7. From these plots, it is clear that when traffic increase, random access will have lower performance as the number of collisions increase. This is the nature of randomized scheme that inherited in CSMA/CA. Our proposed algorithm, however, decreases this collision by allowing to form a sequence of transmission among stations that have data to send. This effect is depicted in Fig. 3.8. Because of that, collision/success ratio tends to decrease after it reaches its peak. This is a desired characteristic for a wireless network in high traffic region.

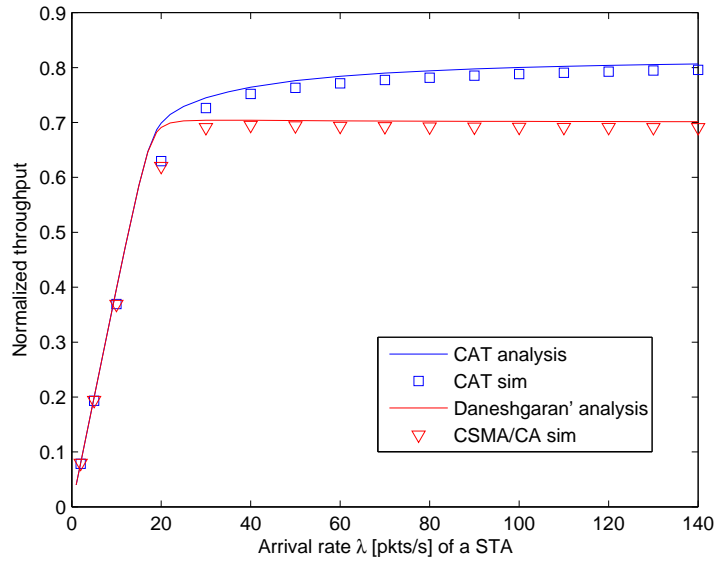

Figure 3.4: Normalized throughput comparison (N=10)

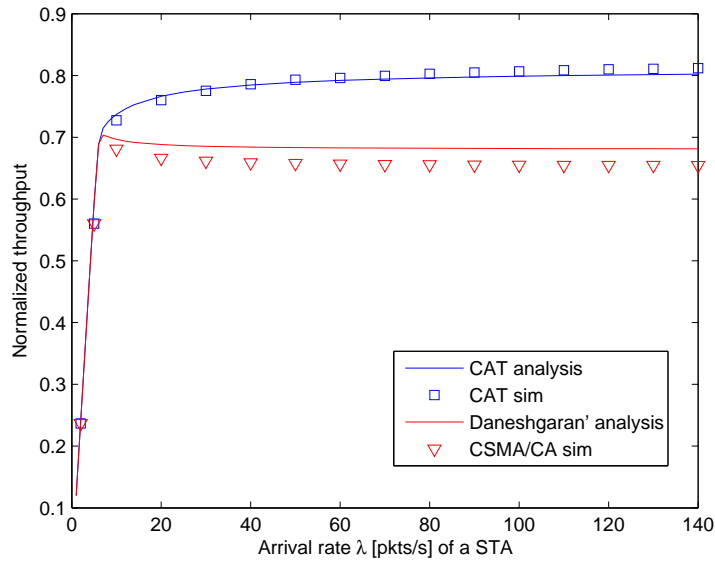

Figure 3.5: Normalized throughput comparison (N=30)

### 3.4.1 Fairness Issue

In this chapter we only considered homogeneous network. Therefore fairness is not a serious issue. In some cases, due to the random nature, we may suffer short term fairness problem in high traffic scenario as all random based protocols. This short

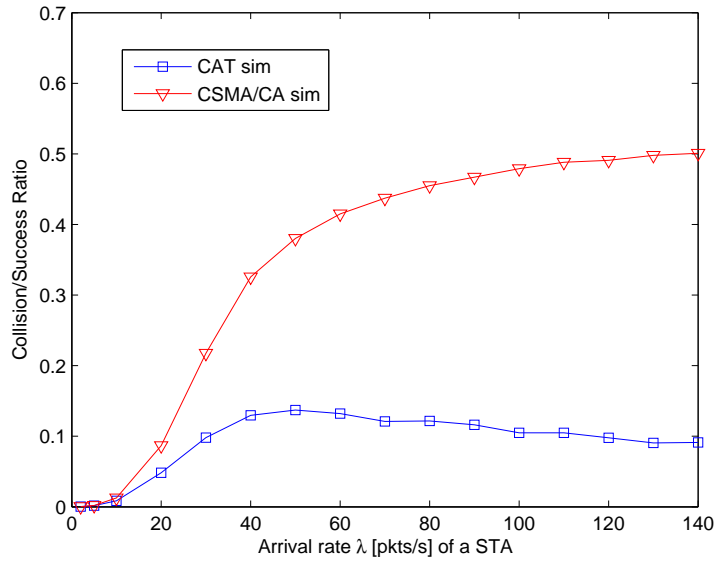

Figure 3.6: Collision/Success Ratio (N=10)

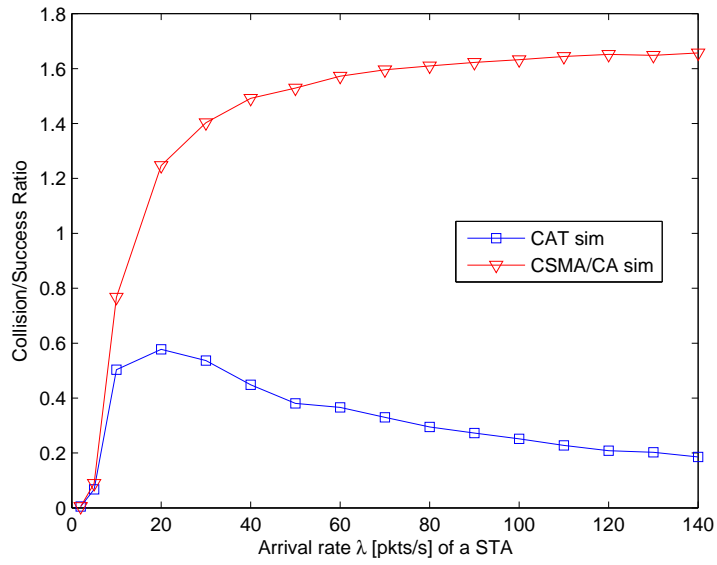

Figure 3.7: Collision/Success Ratio (N=30)

term fairness problem can be address by simple problem such as setting a hard limit as *Max Continuous Transmission* parameter. To evaluate the long term fairness of CAT and to compare with CSMA/CA protocol, we run the simulation with the following

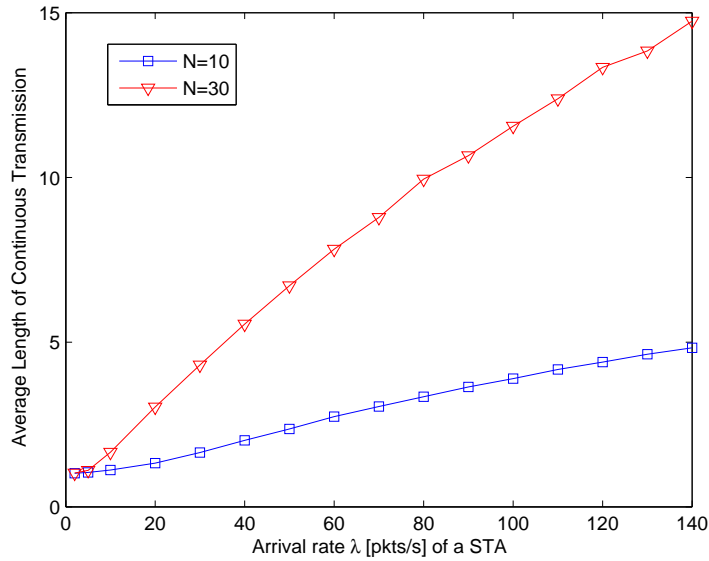

Figure 3.8: Mean Length of Continuous Transmission

setting:  $\lambda = 40$  [pkt/s],  $N = 10$ . The results are given in Table 3.3 with several fairness indexes.

Table 3.3: Fairness Index

Fairness Index	CAT	CSMA/CA
Jain	1.0000	1.0000
Min-Max	0.9826	0.9838
Kullback-Leiber	1.50e-5	2.09e-5

### 3.5 Conclusion

In this chapter we have introduced a new continuous assisted transmission MAC protocol for Ad-hoc network. This scheme is attractive in that it is simple, distributed and efficient protocol for WLAN. The proposed scheme significantly outperforms original CSMA/CA in high traffic region without imposing any central controller. We clearly observe that the wireless stations smoothly change their behavior according to traffic intensity. This scheme can also save power consumption for mobile stations too

when traffic is high by reducing a large number of unnecessary colliding transmissions as well as reducing overhead of continuous successful transmissions.

We also have developed an analysis model for CAT protocol using very simple queueing model. We are now working on more sophisticated queueing models as well as different traffic types.

# Bibliography

- [1] G. Bianchi, "Performance analysis of the IEEE 802.11 distributed coordination function," *IEEE J. Sel. Areas Commun.*, vol. 18, no. 3, pp. 535-547, Mar. 2000.
- [2] D. Malone, K. Duffy, D. Leith, "Modeling the 802.11 distributed coordination function in nonsaturated heterogeneous conditions", *IEEE/ACM Trans. on Networking*, vol. 15, no. 1, pp. 159-172, Feb 2007.
- [3] J. Choi, J. Yoo, C. Kim, "A novel performance analysis model for an IEEE 802.11 wireless LAN," *IEEE Com. Letter*, vol. 10, no. 5, pp. 335-337, May 2006
- [4] F. Daneshgaran, M. Laddomada, F. Mesiti, M. Mondin, "A model of the IEEE 802.11 DCF in presence of non ideal transmission channel and capture effects," *IEEE Globecom 2007*
- [5] A. Kumar, E. Altman, D. Miorandi, M. Goyal, "New insights from a fixed-point analysis of single cell IEEE 802.11 WLANs," *IEEE/ACM Trans. on Networking*, vol. 15, no. 2, pp. 588-601, Jun 2007
- [6] R. G. Gallager, A perspective on multiple access channels, *IEEE Trans. On Information Theory*, p.124 142, IT-31, 1985
- [7] J. G. Proakis, *Digital communications*, 4th edition, McGraw-Hill, 2001
- [8] *IEEE Standard for Wireless LAN Medium Access Control (MAC) and Physical Layer (PHY) Specification*, Nov. 1997

- [9] C. Wang, B. Li, L. Li, A new collision resolution mechanism to enhance the performance of IEEE 802.11 DCF, *IEEE Trans. On Vehicular Technology*, vol. 53, no. 4, Jul. 2004
- [10] C. Wang, W. Tang, A probability-based algorithm to adjust contention window in IEEE 802.11 DCF, *ICCCAS 2004*, vol. 1, pp. 418-422
- [11] S. R. Ye, Y. C. Tseng, A Multichain Backoff Mechanism for IEEE 802.11 WLANs, *IEEE Trans. on Vehicular Technology*, Vol 55, Sept. 2006
- [12] M. Ergen, D. Lee, R. Sengupta, P. Varaiya, WTRPWireless Token Ring Protocol, *IEEE Trans. on vehicular technology*, vol. 53, no. 6, Nov. 2004
- [13] G. Hiertz, D. Denteneer, L. Stibor, Y. Zang, X. P. Costa, B. Walke, The IEEE 802.11 Universe, *IEEE Communications Magazine*, vol. 48, no. 1, pp. 62 - 70, Jan 2010



# Chapter 4

## One-ACK Protocol

In this paper, we developed an analytical frame work for 802.11 One-ACK protocol under saturated condition with imperfect wireless channel. We developed a probabilistic model to handle the retransmissions of fragmentations which are corrupted due to bad channel condition. A modified Markov chain model is introduced to better model the backoff counter operation. The analytical results are verified against NS-2 simulation with great precision.

### 4.1 Introduction

Medium Access Control (MAC) protocol is one of the fundamental parts of telecommunication system. In multiple access systems, a large number of users share a common communication channel to transmit information to a receiver [2]. MAC schemes are used to control the access of active nodes to the shared channel [1]. In wireless communications networks, MAC scheme can significantly affect the overall performance of the network systems.

In recent years, much interest has been involved in studying 802.11 DCF (Distributed Coordination Function) protocol for WLAN such as [4]-[8]. 802.11 DCF protocol [3] is the fundamental access method used to support asynchronous data

transfer on a best effort basis. To address the issue of big frame transmission under imperfect wireless channel, fragmentation is proposed as a promising technique. In [10], performance evaluation has been carried out in erroneous channel by means of simulation without employing RTS/CTS exchange messages. The idea of using one ACK for fragmentation transmission has already been introduced in [11] and further developed in [12].

Though much effort has been focused on the simulation work, there are not many reports on the analysis toward this trend. The analysis of 802.11 DCF by using Markov chain has been carried out by Bianchi in his legacy paper [4]. Since then this model has been used as standard model for most of the developments in the analysis of WLAN under various conditions. In this paper, we based on the Markov chain model of [4] to develop our analytical framework for One-ACK protocol. This modified model has corrected the shortcoming of [4] and greatly increases the precision of analytical results.

The rest of this paper is organized as follow: Section II briefly reviews the One-ACK protocol. Section III proposes analytical model. Section IV compares our model with simulation results of NS-2.33 [9]. Conclusions are drawn in Section V.

## 4.2 One-ACK protocol

The nature of shared wireless environment such as Wireless LANs makes the designing appropriated protocols become a challenging task. Moreover, the wireless channel itself is inherently unpredictable and unreliable. Therefore, sending large frames over that noisy channel is much more difficult and may result in unnecessarily retransmission. Reducing transmission time of a frame will subsequently reduce the chance of being corrupted by channel imperfection. This obvious solution does not directly translate to better wireless network. Any transmission will carry with it a certain

amount of header. Reducing frame size will subsequently reduce the efficiency of that transmission. In this regards, fragmentation becomes as a promising technique to improve the system performance as a whole. The process of fragmentation is quite simple and is given in Fig. 4.1.

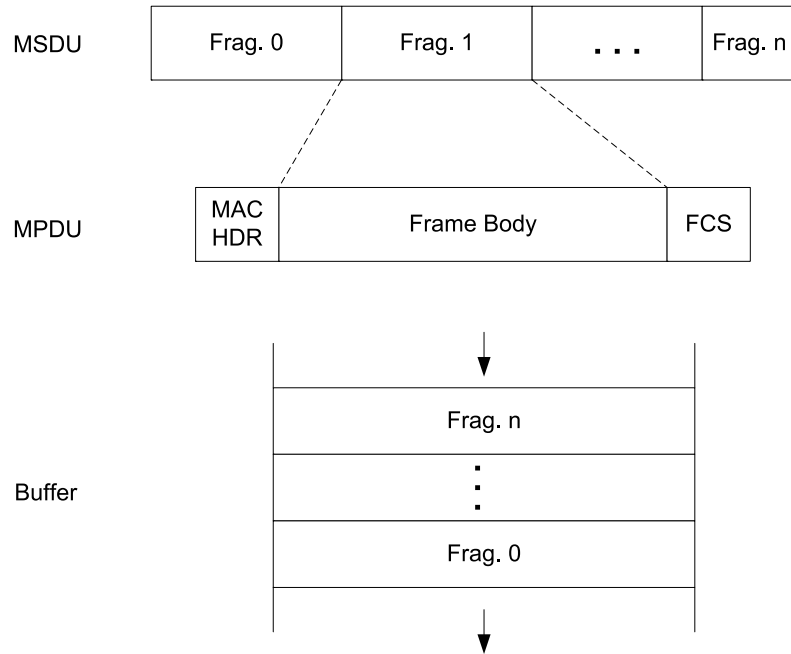

Figure 4.1: Fragmentation process

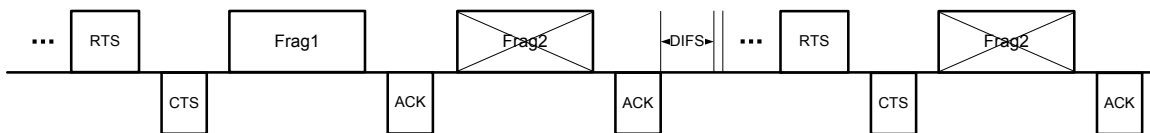

Figure 4.2: 802.11 Fragments transmission process under erroneous channel

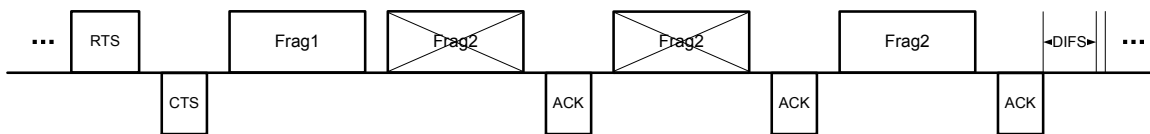

Figure 4.3: One-ACK transmission process under erroneous channel

Fragmentation is a process of dividing a frame into several smaller fragments. The purpose of having fragment is to increase throughput due to bad channel. If error happens at a small fraction of the transmission, then we only need to retransmit that portion of data instead of retransmitting the whole frame.

The standard specifies that the MAC Service Data Unit (MSDU) from LLC layer is divided into several smaller fragments by *dot11FragmentationThreshold*, except for the last fragment. Each fragment is encapsulated with MAC header and FCS before it is actually transmitted. All the fragments are kept in buffer in both transceivers. According to standard, after fragmentation process, each fragment will be transmitted independently with separated ACK followed. This permits transmission retries to each individual fragment, rather than the whole frame [3].

Once a station wins the access to channel, it will continuously send fragments until either all the fragments of the MSDU have been sent or last ACK is not received. The successive transmission of the MSDU is called fragmentation burst. After DIFS, the channel will be free for other station to access. If a fragment fails to receive correctly, the sender should perform backoff procedure to contend the channel again to retransmit that fragment. This process, while enforces the fairness among stations, will add additional overhead to the transmission process. Moreover, if the fragment burst is broken by fragment failure, the receiver must support concurrent reception of fragments transmitted from other neighbor nodes [10]. The IEEE 802.11 notes that receiver (AP) should be capable to handle at least three different fragment busts [3]. This aspect will put a heavy burden on AP in bad environment.

The 802.11 DCF fragmentation process introduces extra overhead and becomes the main critical point for other proposals. One-ACK scheme has been introduced to reduce such big overhead. In One-ACK, fragments will be transmitted continuously. The ACK is transmitted only at the end of fragmentation burst for receiver to report back which fragments are corrupted. That incorrectly received fragments will be

resent right after ACK with SIFS separation. Because no other station could access the channel during this process, retransmission is handled without any contention. This technique might raise the question of short term fairness as the sender could possibly hold the channel for quite a long period. The simulation results in [11] confirm that this is a negligible issue here. The system could maintain fairness at the same level of legacy fragmentation scheme while throughput is significantly improved.

In the upcoming 802.11n standard with very high transmission rate, the need for aggregating several small fractions of larger data to transmit becomes critical and unavoidable. The remaining question is how could we properly address this issue? One-ACK scheme is a logical effort to address this new challenge. Fig. 4.2 graphically presents the idea of transmitting fragments in bust. Fig. 4.3 shows a typical transmission process of the One-ACK protocol. Comparing Fig. 4.2 and 4.3, we could conclude that the proposed One-ACK protocol could increase network throughput significantly by effectively reducing unnecessary overhead and contention time. This relative increment can be further improved when we consider the ever increasing transmission rate of WLAN technology. Compare to 802.11 specifications, One-ACK could save transmission time at least by:

$$(n - 1)(SIFS + T_{ACK})$$

where  $n$ : number of fragment per frame;  $T_{ACK}$  is time for transmitting ACK frame in basic rate.

To accommodate the modification of transmission, we will need a mechanism to report back to the sender which fragments are being corrupted. With this information, the sender can resend the proper unsuccessful parts of the large data frame. In One-ACK protocol, this mechanism is realized in ACK frame by adding a 2-byte *Fragment Counter* field to the original ACK frame. Each bit in this field represents

a fragment reception condition, which is 0 for success and 1 for failure. By reading this field, the sender knows which fragments need to be re-sent and therefore compile resending frame accordingly. The configuration of the modified ACK frame is depicted in Fig. 4.4.

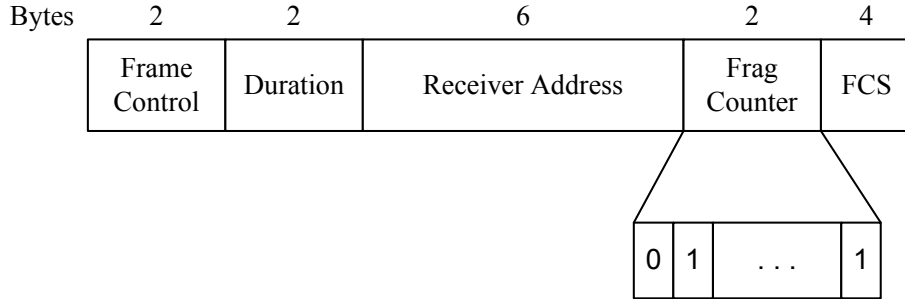

Figure 4.4: ACK frame of One-ACK protocol

### 4.3 Analytical model for One-ACK protocol

One the frequently cited model for analytical work is the Markov chain model in [4]. Though this model could provide very close analytical model, we could visibly observe that when the number of station increase so as the error. In this part, we introduce a modified model that could cope with this problem. The main issue in [4] is probability transition of backoff state is equal to 1,  $p(b_{i,k}|b_{i,k+1}) = 1$ . This assumption, while violating the standard, makes the model extremely simple and elegant. According to standard, station should hold its backoff counter in busy channel and restart the countdown process from that state. Setting  $p(b_{i,k}|b_{i,k+1}) = 1$  means that the backoff counter will reduce faster. Under normal condition, this assumption, though incorrect, could still produce a relatively closed form solution. However, its shortcoming could result in noticeable differences between simulation and analytical results when applying directly to our work. Therefore, in this paper we take that probability into consideration by setting  $p(b_{i,k}|b_{i,k+1}) = q$ . Whenever the channel is idle (with probability  $q$ ) the back off counter will be reduced. The detail estimation of  $q$  will be

given in the next section. As we will see in the later section, the modified model could produce much closer results against simulation. The proposed model is given in Fig. 4.5

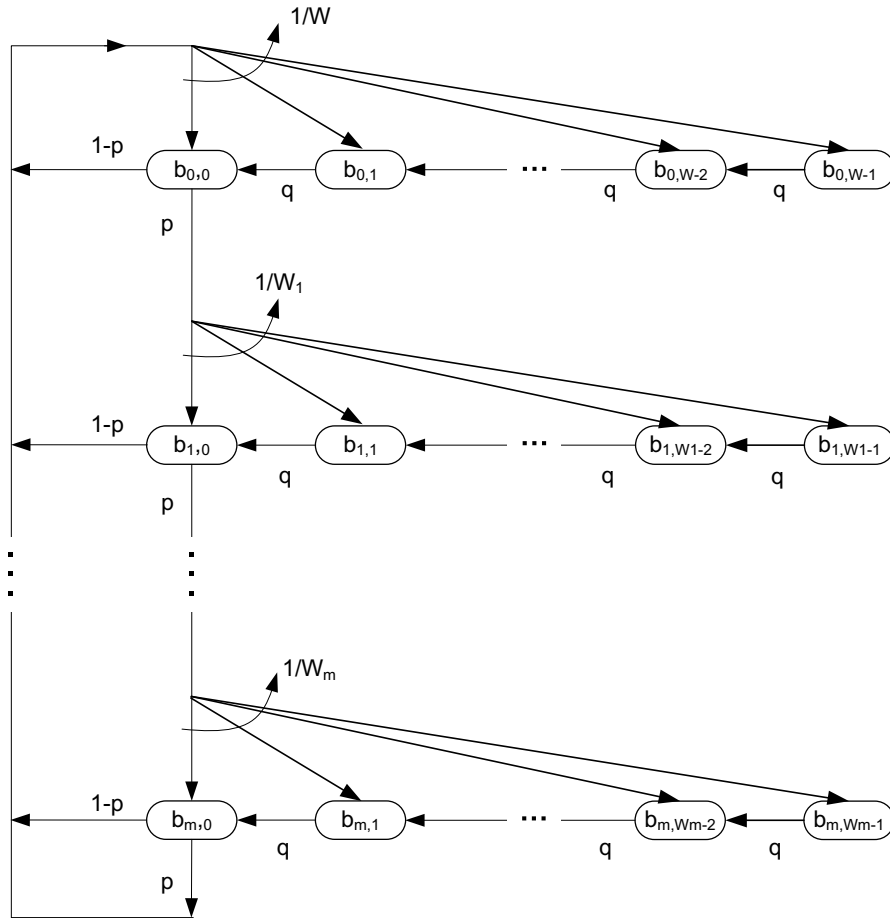

Figure 4.5: Modified Markov Model

We supposed that the readers are familiar with Markov Model in [4]. We mainly focus on the differences in the modified model. Main parameters are given in table 4.1

Under this model:

$$b_{i,k} = \frac{W_i - k}{W_i} \frac{1}{q} p^i b_{0,0} \quad 0 \leq i \leq m; 0 \leq k \leq W_i - 1 \quad (4.1)$$

Table 4.1: Parameters Definition

$N$	Total number of stations in the network
$n$	Number of fragments per frame
$m$	Maximum retransmission
$W$	Minimum contention window
$W_i = 2^i W$	Contention window at retransmission $i$ ( $\leq m$ )
$b_{i,k}$	Stationary state of Markov chain where: $i$ : retransmission times, $k$ : back-off counter's value. Station will transmit when $k = 0$
$P_I$	Probability of idle slot
$P_s$	Probability of successfully content for channel
$P_c$	Probability of collision transmission
$P_{str}$	Probability of successful transmission a frame
$P_{xtr}$	Probability of dropping a frame due to erroneous channel
$\rho$	FER of a fragmentation
$q$	Probability of reducing backoff counter
$\tau$	Probability that a station transmit its data packet
$p$	Collision probability.

Based on the normalized condition, we have:

$$\sum_{i=0}^m \sum_{k=0}^{W_i-1} b_{i,k} = 1 \quad (4.2)$$



substituting (4.1) into (4.2) we then have:

$$\begin{aligned}
\sum_{i=0}^m \sum_{k=0}^{W_i-1} b_{i,k} &= \\
\frac{b_{0,0}}{q} \sum_{i=0}^m \left\{ p^i \sum_{k=0}^{W_i-1} \frac{W_i - k}{W_i} \right\} &= \\
\frac{b_{0,0}}{q} \sum_{i=0}^m \left\{ p^i \frac{W_i + 1}{2} \right\} &= \\
\frac{b_{0,0}}{2q} \left\{ W \frac{1 - (2p)^{m+1}}{1 - 2p} + \frac{1 - p^{m+1}}{1 - p} \right\} &= 1
\end{aligned}$$

Therefore:

$$b_{0,0} = \frac{2q}{W \frac{1 - (2p)^{m+1}}{1 - 2p} + \frac{1 - p^{m+1}}{1 - p}} \quad (4.3)$$

To find the distribution of this model, we should find solution of this set of equations:

$$\begin{cases} \tau = \sum_{i=0}^m b_{i,0} = \frac{1 - p^{m+1}}{1 - p} \\ p = 1 - (1 - \tau)^{N-1} \\ q = (1 - \tau)^{N-1} \end{cases} \quad (4.4)$$

Those above are equations regulate the behaviour of one station. We would like to further explain the meaning of equations in Eq. 4.4: The first equation says that a station will transmit its data when the backoff counter value equal to zero. In the Markov chain model, it is the  $b_{i,0}$  states. The third equation says that whenever channel is free for a slot time duration ( $\sigma$ ), the backoff counter will be reduced by one according to [3]. This condition is realized when all other ( $N - 1$ ) stations do not transmit data packet. The second equation means that collision occurs when other

station(s) also transmit(s) data at the same time, which is the reversed condition of the third equation.

To obtain the network throughput, we should take the network view point:

$$\begin{cases} P_I = (1 - \tau)^N \\ P_s = N \tau (1 - \tau)^{N-1} \\ P_c = 1 - P_I - P_s \end{cases} \quad (4.5)$$

$P_s$  is the probability that one station wins the channel, but that does not directly translate to successful reception of that transmission. Due to the random nature of wireless channel, that transmission is subjected to corruption. Therefore  $P_s$  is further break down to the following two cases:

$$\begin{aligned} P_{str} = & \sum_{i_1=0}^n \binom{n}{i_1} \rho^{i_1} (1 - \rho)^{n-i_1} \times \dots \times \\ & \sum_{i_k=0}^{i_{k-1}} \binom{i_{k-1}}{i_k} \rho^{i_{k-1}} (1 - \rho)^{i_{k-1}-i_k} \times \dots \times \\ & \binom{i_{m-1}}{0} (1 - \rho)^{m-1} \end{aligned} \quad (4.6)$$

$$\begin{aligned} P_{xtr} = & \sum_{i_1=1}^n \binom{n}{i_1} \rho^{i_1} (1 - \rho)^{n-i_1} \times \dots \times \\ & \sum_{i_m=1}^{i_{m-1}} \binom{i_{m-1}}{i_m} \rho^{i_{m-1}} (1 - \rho)^{i_{m-1}-i_m} \end{aligned} \quad (4.7)$$

Where  $n$  is the number of fragments in the original frame,  $i_{k-1}$  is the number of corrupted fragments, due to bad wireless channel, in the last (re)transmission and  $i_k$  is the number of corrupted fragments in this retransmission. In success transmission, we will have  $i_k = \dots = i_m = 0$ . It means that we successfully transmit the frame

to AP before Retransmission limit is reached. And in the failure transmission, we will have  $i_m > 0$ . Those equations (4.6-4.7) are exhausted counting process for all probability branches of the whole probability space.

Associate with those probabilities are the required time to transmit those fragmentations:

$$T_{s/xtr} = T_{header} + (SIFS + T_{frag}) \times \sum_{k=0}^m i_k \quad (4.8)$$

with the understanding that  $i_0 = n$  and  $T_{frag}$  is time for transmitting one fragment.

$$T_{header} = \begin{array}{l} RTS + CTS + ACK + DIFS + \\ 2 \times SIFS \end{array} \quad (4.9)$$

and collision transmission will cost:

$$T_c = EIFS \quad (4.10)$$

Based on the above equations, we could now express the network throughput as follow:

$$S = \frac{P_s P_{str} T_{data}}{P_s (T_{str} + T_{xtr}) + P_s T_c + P_I \sigma} \quad (4.11)$$

where  $T_{data}$  is the actual time required to transmit the data.

## 4.4 Simulation verification

In this section, we validate this analysis with simulation results of Ns-2.33 implementation. We setup our simulations as follow: mobile stations are placed randomly

on a circle with radius  $R = 30\text{m}$ . An access point ( $AP$ ) is placed at the center of the circle. This arrangement complies with the assumption that channel condition is statistical identical for every stations. Each simulation runs for 200 [sec] and the first warm up period 10 [sec] is eliminated. Simulation is carried out 5 times for each setting. Throughput is evaluated by averaging over those 5 samples. Arrival rate for each station is high enough to guarantee saturation condition. We assume that all control packets will be transmitted without corruption. This is a reasonable assumption as those packets are transmitted in basic rate, which is much lower than the transmission rate of data packets. Main parameters setting are given in table 4.2. The Bianchifs analytical model is revised to consider packet drop ( $m$ ) case. This is a necessary minor revision to have a meaningful comparison with our model.

Table 4.2: Simulation Parameters of 802.11 for Ns-2

Parameter	Value
Frame Size	2048 bytes
Fragment Size	1024 bytes
RTS	160 bits
CTS	112 bits
ACK	128 bits
Basic(RTS, CTS, ACK) rate	6, 54 Mbps
DATA rate	24, 54, 108, 432 Mbps
Number of STA ( $N$ )	1, 10, 20, 30
Retransmission Limit	2
Retrial Limit	6

Table 4.3: Error between analytical model and simulation of 1 Station

$\rho$	0.5	0.3	0.1	0.05	0.03	0.01
<b>Error(%)</b>	0.5729	0.0821	0.0486	0.1727	0.1495	0.0792

The main comparisons are presented in Fig. 4.6 - 4.10. From these figures, we observe that the analytical model consistently agrees well with NS-2 simulation outputs

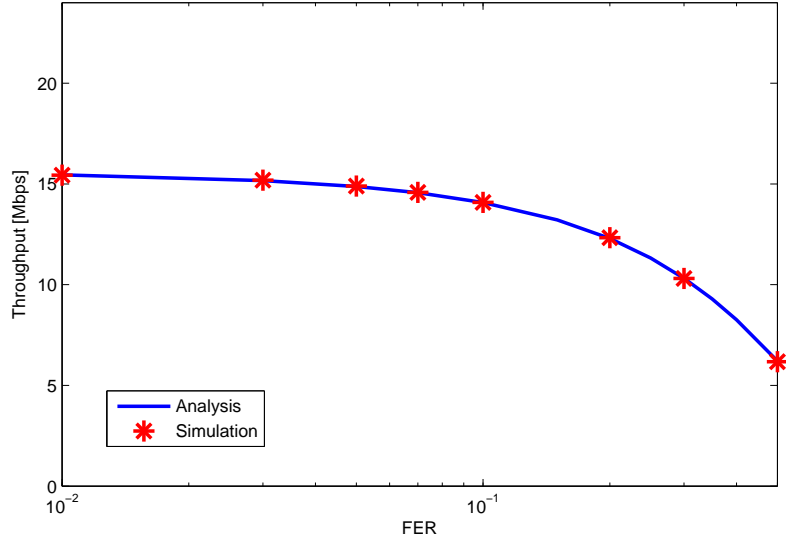

Figure 4.6: Network Throughput ( $N = 1$ , Data/Basic rate = 24/6 Mbps)

Table 4.4: Error (%) between analytical model and simulation

$\rho$		0.5	0.1	0.01	0.001	0.0001
<b>Fig. 4.7</b>	Modified Model	0.1341	0.0666	0.0713	0.0475	0.0607
	Bianchi Model	0.8011	0.9343	1.0039	0.9875	1.0012
<b>Fig. 4.8</b>	Modified Model	0.0856	0.2241	0.2213	0.2124	0.2145
	Bianchi Model	0.7052	1.0088	1.0600	1.0571	1.0596

Table 4.5: Throughput of 30 Station (54/6 Mbps)

$\rho$	0.1	0.05	0.01
<b>Ns-2</b>	0.410899	0.431890	0.446988
<b>Modified model</b>	0.411803	0.433204	0.448426
<b>Bianchi's model</b>	0.400943	0.421378	0.435825

under various simulation settings. They are much closer to the simulation output than the Bianchifs model. To further investigate the advantage of analytical model, we calculate the relative error in case of a WLAN network with only one and many stations. The simplest case's result is given in table 4.3. Under this simplest scenario, this modified model and the original Bianchi's model are the same as  $q = 1$ . The

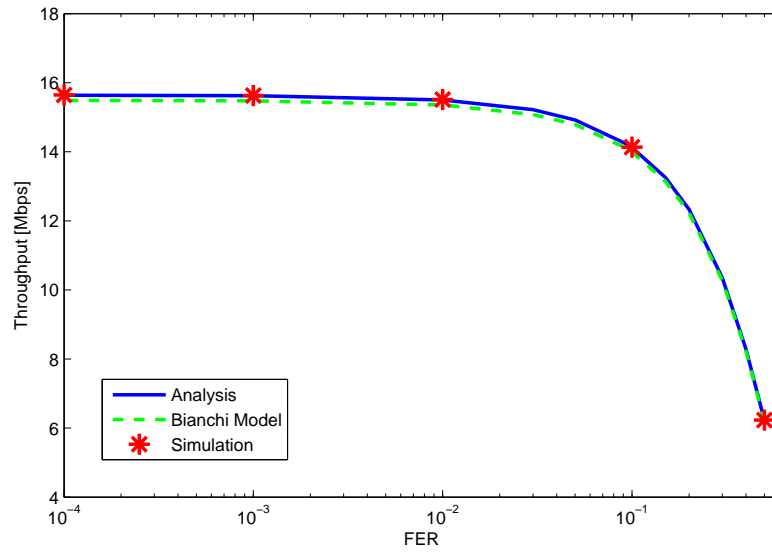

Figure 4.7: Network Throughput ( $N = 20$ , Data/Basic rate = 24/6 Mbps)

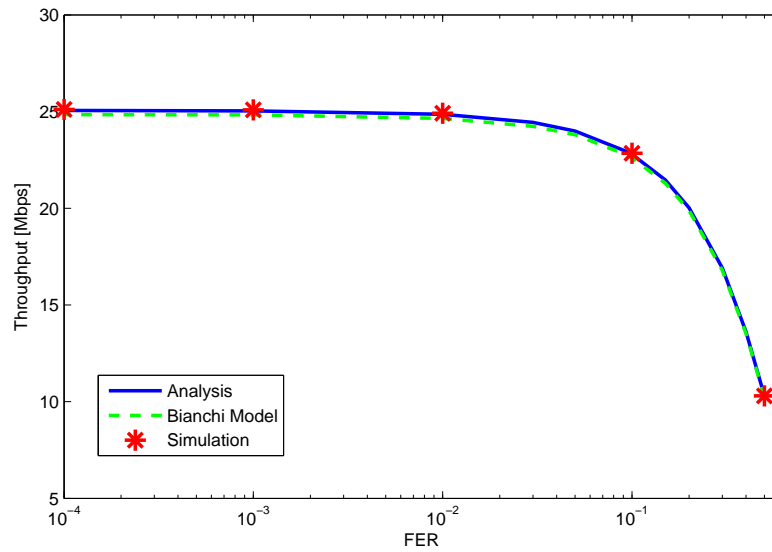

Figure 4.8: Network Throughput ( $N = 10$ , Data/Basic rate = 54/6 Mbps)

errors, in percentage, become bigger in Fig. 4.7 - 4.8 as in table 4.4. Those differences are quite acceptable.

However, simulation results confirm that, when the number of stations increase, the differences between Bianchi's model and the modified model could be quite signif-

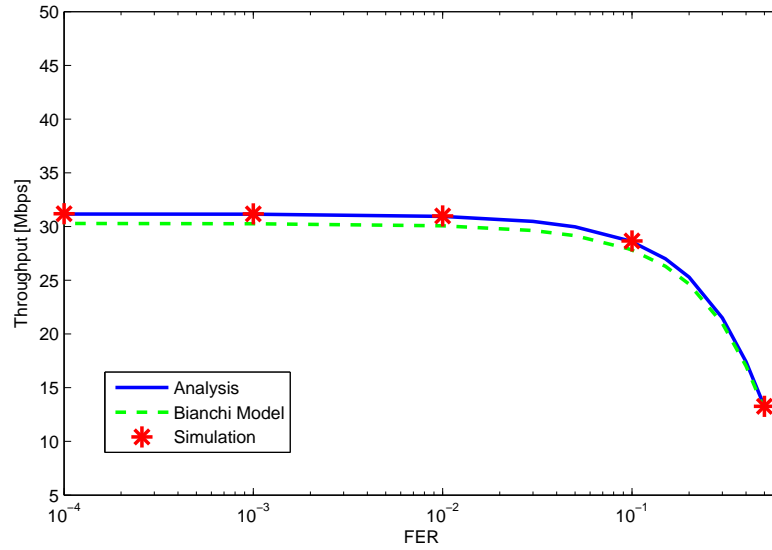

Figure 4.9: Network Throughput ( $N = 30$ , Data/Basic rate = 108/6 Mbps)

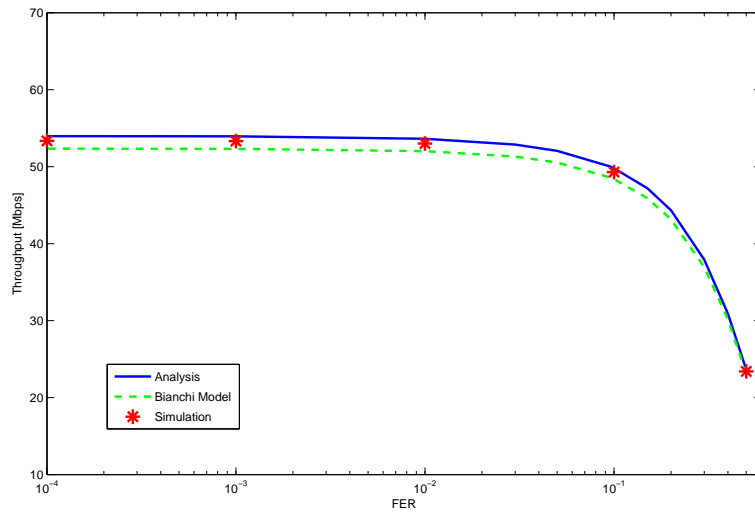

Figure 4.10: Network Throughput ( $N = 30$ , Data/Basic rate = 432/54 Mbps)

icant as indicated in table 4.5. We therefore believe that our developed model could precisely capture the throughput of this One-ACK protocol.

The advent of 802.11n standard opens up the possibility for very high transmission data rate that exceeds the current 802.11a standard. To illustrate performance of OneACK protocol under this condition, we run simulation for different setting of Data

Rate and Basic Rate. The results are presented in Fig. 4.9 and 4.10. The results of these figures show that under the very high speed transmission realm, MAC overhead will have strong effect on the network throughput.

## 4.5 Conclusion

In this chapter we have introduced an analytical model based on Markov chain to analyze One-ACK protocol under saturated condition. Analysis and simulation results shows that our framework could estimate the performance of One-ACK protocol with great accuracy. The modified Markov chain model developed in this paper yields much better accuracy over legacy model in [4]. In this paper, we have only considered the random noise scenario. A more interesting model for busy and fading channels is now under investigation. We also have just attacked the saturated condition, in which the effect of queue length is unimportant. In real WLAN system, those parameters are of primary concern for both research and practical purposes. Therefore our next step is to develop a model to analyze system under unsaturated condition.



# Bibliography

- [1] R. G. Gallager, A perspective on multiple access channels, *IEEE Trans. On Information Theory*, p.124-142, IT-31, 1985
- [2] J. G. Proakis, *Digital communications*, 4th edition, McGraw-Hill, 2001
- [3] *IEEE Standard for Information technology Telecommunications and information exchange between systems Local and metropolitan area networks Specific requirements Part 11: Wireless LAN Medium Access Control (MAC) and Physical Layer (PHY) Specifications*, June, 2007
- [4] G. Bianchi, "Performance analysis of the IEEE 802.11 distributed coordination function," *IEEE J. Sel. Areas Commun.*, vol. 18, no. 3, pp. 535-547, Mar. 2000.
- [5] D. Malone, K. Duffy, D. Leith, "Modeling the 802.11 distributed coordination function in nonsaturated heterogeneous conditions", *IEEE/ACM Trans. on Networking*, vol. 15, no. 1, pp. 159-172, Feb 2007.
- [6] J. Choi, J. Yoo, C. Kim, "A novel performance analysis model for an IEEE 802.11 wireless LAN," *IEEE Com. Letter*, vol. 10, no. 5, pp. 335-337, May 2006
- [7] F. Daneshgaran, M. Laddomada, F. Mesiti, M. Mondin, "A model of the IEEE 802.11 DCF in presence of non ideal transmission channel and capture effects," *IEEE Globecom 2007*

- [8] A. Kumar, E. Altman, D. Miorandi, M. Goyal, "New insights from a fixed-point analysis of single cell IEEE 802.11 WLANs," *IEEE/ACM Trans. on Networking*, vol. 15, no. 2, pp. 588-601, Jun 2007
- [9] *Ns-2 network simulator*, <http://www.isi.edu/nsnam/ns/>
- [10] Y. Xi, J. B. Wei, Z. W. Zhuang, B. S. Kim, Performance Evaluation, Improvement and Channel Adaptive Strategy for IEEE 802.11 Fragmentation Mechanism, *IEEE Symposium on Computer and Communication*, Jun 2006
- [11] T. Nguonly, S. Shimamoto, One-ACK Scheme for Fragmentation Burst in Wireless LANs, *IEICE General Conference BS-4-13*, Matsuyama, Japan, Mar 2009
- [12] T. Nguonly, S. Shimamoto, Block-based Adaptive Fragmentation Scheme in IEEE 802.11 Wireless LANs, *IEICE Society Conference BS-10*, Niigata, Japan, Sep 2009

## Chapter 5

# Intelligent Local Avoided Collision (*iLAC*) MAC Protocol for Very High Speed Wireless Network

Future wireless communication systems aim at very high data rates. As the medium access control (MAC) protocol plays the central role in determining the overall performance of the wireless system, designing a suitable MAC protocol is critical to fully exploit the benefit of high speed transmission that the physical layer (PHY) offers. In the latest 802.11n standard [2], the problem of long overhead has been addressed adequately but the issue of excessive colliding transmissions, especially in congested situation, remains untouched. The procedure of setting the backoff value is the heart of the 802.11 distributed coordination function (DCF) to avoid collision in which each station makes its own decision on how to avoid collision in the next transmission. However, collision avoidance is a problem that can not be solved by a single station. In this chapter, we introduce a new MAC protocol called Intelligent Local Avoided Collision (*iLAC*) that redefines individual rationality in choosing the backoff counter value to avoid a colliding transmission. The distinguishing feature of *iLAC* is

that it fundamentally changes this decision making process from collision avoidance to collaborative collision prevention. As a result, stations can avoid colliding transmissions with much greater precision. Analytical solution confirms the validity of this proposal and simulation results show that the proposed algorithm outperforms the conventional algorithms by a large margin.

## 5.1 Introduction

Today most of the personal PCs, laptops, cell phones, etc., are equipped with wireless LAN technology. The increasing popularity of WLAN technology has stimulated continuing investigations by industrial and academic researchers which results in several amendments made to the basic 802.11 standard and improvements toward high speed networks. The 802.11n amendment [2] consists of many enhancements that improve WLAN range, reliability, and throughput.

At the physical (PHY) layer, advanced signal processing and modulation techniques have been added to exploit multiple antennas and wider channels which boost data rates up to 600 Mbps [3].

Although faster raw transmission speed has been attributed to the PHY layer, it is the medium access control (MAC) protocol that regulates the actual throughput of a station. Thus innovation in MAC layer is necessary to take full advantage of the very high speed transmission technology of the lower PHY layer. One of the major problems that reduces the channel efficiency is MAC's overhead. In WLAN, the MAC's overhead falls into two categories:

- Transmission overhead including the preamble, frame headers, inter frames durations (SIFS, DIFS) and acknowledgement.
- Contention overhead including wasteful colliding transmissions and free time slots due to the random backoff period.

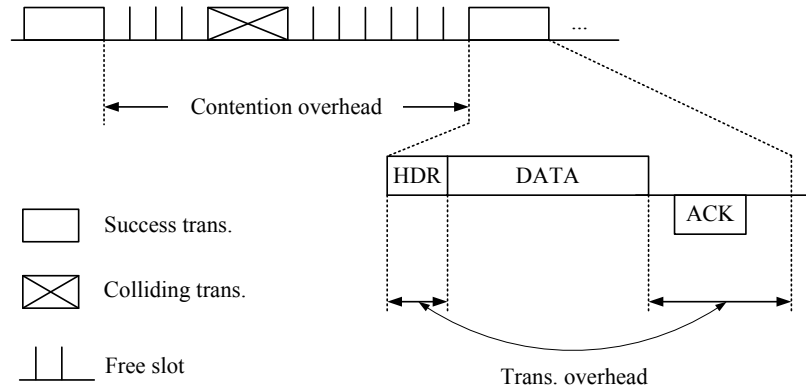

Figure 5.1: Overhead in 802.11 DCF

The overheads are depicted in Fig. 5.1. Channel efficiency is estimated as the time to transmit data payload over the total transmission process. The achievable throughput is usually lower than the maximum throughput that the PHY can support. However, with the recent 802.11n amendment, the actual channel usage is quite poor because overhead time becomes dominant for small frame size transmissions. To partially counter the adverse effect, 802.11n introduces:

- Block Acknowledgment to reduce the number of ACKs that a receiver must send to a transmitter to confirm frames delivery,
- Frame Aggregation to increase the payload by aggregating several frames into one single transmission.

The strengths of those amendments have been investigated in [8]-[11]. Another significant problem is wasteful colliding transmissions. Let's take a two-station case for further clarification. Suppose  $W = 8$  and all stations have data to send. Even though there are more than enough available slots for two stations, collisions still occur at a fixed probability of  $\frac{1}{8}$ . As the number of stations increases, the probability escalates quickly. If collision occurs, DCF will infer that the network is crowded and tries to reschedule the retransmission at a later time by doubling  $W$ . The backoff

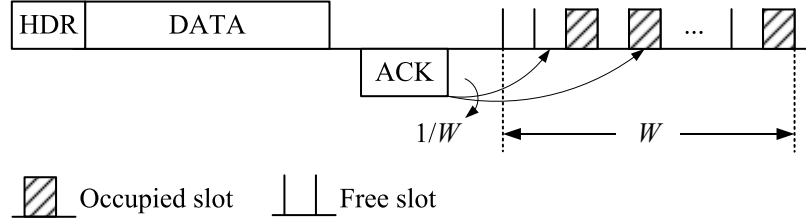

Figure 5.2: Backoff decision in DCF

counter is set based on this parameter in the hope of lowering collision probability. In the two-station case, that decision leads to even more inefficient channel usage by introducing many additional free time slots.

If we look into the recent development of MAC layer, it is surprising to find that this serious problem has not been addressed. The collision avoidance algorithm has been kept unchanged since the original version of 802.11 [1]. Stations are still struggling to gain a channel access, especially in a dense environment.

The 802.11 DCF protocol is a random access scheme, based on the carrier sense multiple access with collision avoidance (CSMA/CA) protocol. When a station has a packet to send, it will first sense the channel during a distributed interframe space (DIFS) period. If the channel is idle during this time, the station will transmit its packet, otherwise, it will go into collision avoidance state. The station will continuously monitor the channel until it becomes idle for DIFS again. The station then tries to avoid collision by a random access scheme called exponential backoff scheme. The channel is slotted and transmission is allowed at the beginning of a slot. A contention window,  $W$ , in the range of  $[CW_{min}, CW_{max} = 2^m CW_{min}]$  is specified in advance. The backoff counter is randomly chosen in the range of  $[0, W)$ . At first,  $W$  is set to  $CW_{min}$ ; after each unsuccessful transmission,  $W$  is multiplied by two until it reaches  $CW_{max}$  value in order to reduce the probability of collision.

The process of setting the backoff counter is illustrated in Fig. 5.2. It is clear that the backoff procedure is the key element that helps stations to avoid a colliding trans-

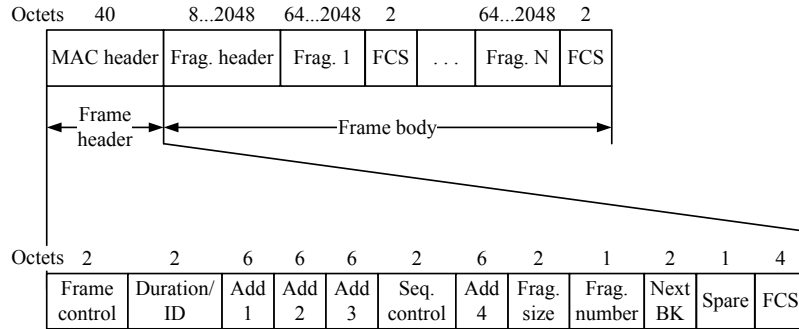

Figure 5.3: Data frame structure

mission. However, it is not certain that the transmission will be immune from collision or not because the procedure only reflects the individual views on the channel status. This paper argues that such uniformly distributed randomization approach is flawed and is not an optimum solution to the problem of collision avoidance. Addressing this major problem is the main target of this paper.

As collision limits the improvement of the user perceived throughput, even the PHY layer offers a very high transmission speed, the MAC layer still can not take much of the advantage of the lower layer. In previous research [6], the authors proposed to piggyback a data frame if the receiving station needs to send back to the sender. However, in a dynamic wireless network, the impact of this proposal is limited.

The paper is organized as follows: Section 1 reviews the current protocol and identifies the core problem of CSMA/CA. Section 2 presents a general guideline to approach the above problem and details the solution by introducing a novel protocol called *iLAC*. Section 3 analyses *iLAC* by using Markov chain tool in fully connected, saturated network conditions. Section 4 verifies the advantages of *iLAC* against DCF under various settings. Finally, conclusions are drawn and future developments are presented in Section 5.

## 5.2 Protocol description

This section presents a rationale for a new approach to address the colliding transmission problem and proposes a new MAC protocol.

The problem of the current 802.11 MAC protocol is that it attempts to solve the colliding transmissions on individual basis which, therefore, does not have the necessary capability to support a collaborative decision making. To foster a collaboration among stations, it is necessary to develop a new procedure that encourages information sharing. Wireless channel could be a perfect medium for that purpose as every station can listen to the channel and the standard even allows them to decode a part of the ongoing transmitting frames. This special feature is beneficial but has been limitedly exploited in wireless MAC protocol design, such as [6] and [7].

In DCF, the frame that does not target a station will simply be discarded. We argue that this is a misleading decision as other stations can take advantage of this frame as well. Instead of being simply ignored, that overhead should be a prime tool to solve the collision problem effectively and economically.

Considering this, we introduce a new MAC protocol called Intelligent Local Avoided Collision (*iLAC*). The idea here is quite simple and straightforward. Before a transmission, a station must decide an integer value to set its backoff counter after the transmission. The station then releases that value so as other stations in the vicinity know how to avoid collision with him in the future transmission. It is important that stations should keep a local database of register slots. Whenever a station needs to set its backoff counter, it will draw a random number other than the ones in the {Register slots} set to prevent a colliding transmission. As such, the distribution of random numbers that a station draws for its backoff counter is not a uniform but a real time, discrete, location specific distribution. This procedure is different from DCF scheme in which the set to determine the backoff counter state is flexible whereas the one in DCF is predefined.



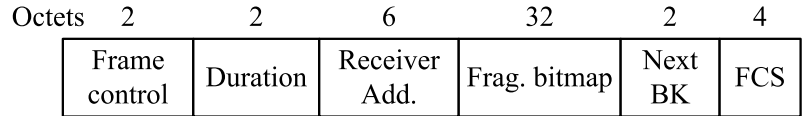

Figure 5.4: ACK frame structure

The two frames under investigation are: data frame and ACK frame which are depicted in Fig. 5.3-5.4. The novel information injected to those frames is the field *Next BK* which stands for *Next Backoff value*. The following transmission flow explains the merits of this newly added field:

1. Before any transmission, station *A* draws its intended future backoff counter value and then copies that value into the field *Next BK*. Suppose station *A* sends the data frame successfully. The stations within station *A*'s communication range will update their database, *Registerslots*, with the value of the *Next BK* field.
2. Receiving station acknowledges by sending back ACK frame where the *Next BK* value is repeated. Other stations which can decode this field will also update their database, *Registerslots*, accordingly.
3. After receiving ACK, station *A* sets its backoff counter by the value in the *Next BK* field.
4. Stations which would like to send data will draw a random value for their own backoff counters. This value should be different from the ones in its database to prevent collision. This strategy is a rational choice because it will ultimately maximize network utility.

The above transmission flow is depicted in Fig. 5.5. Four mobile stations *A*, *B*, *C* and *D* transmit to Access Point. Suppose station *A* wins the channel first as in Fig. 5.5 (a), it takes a random number, that is not in its {Register slots} set, for the *Next*

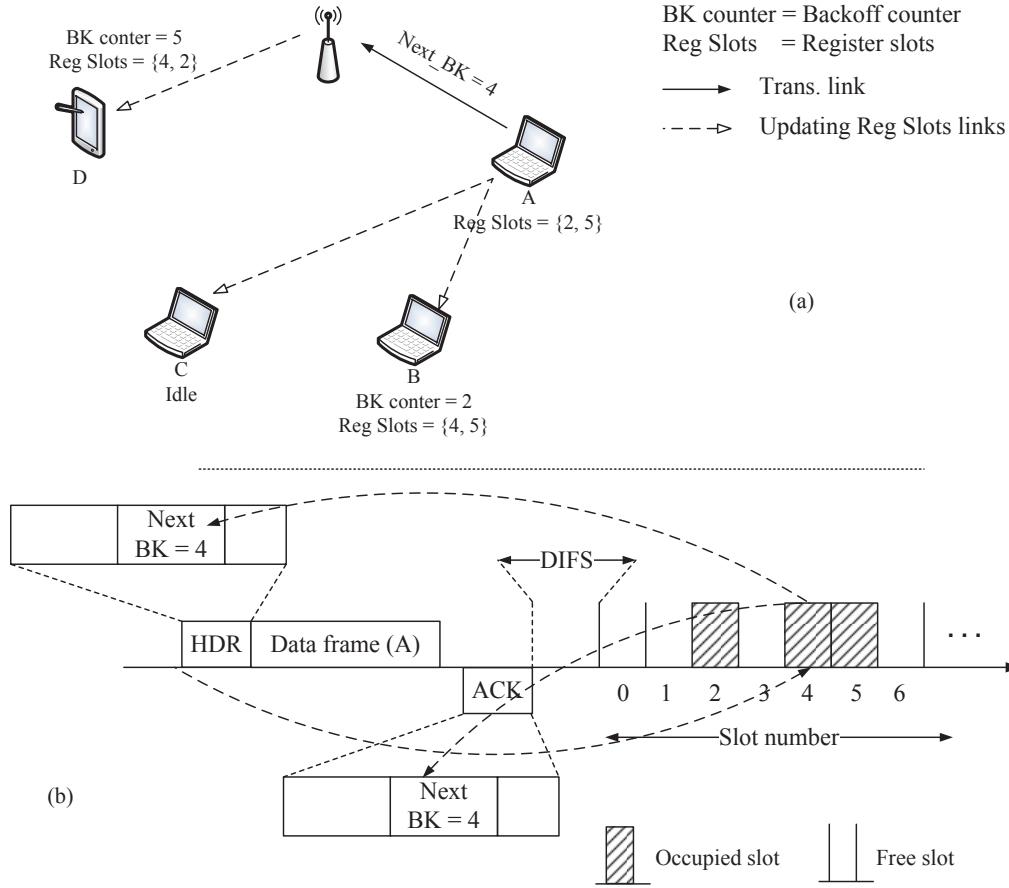

Figure 5.5: iLAC's transmission sequence

$BK$  field, e.g. 4. Supposedly  $W = 16$ , then the process is presented concisely by the function:

$$Next\_BK = RAND\{[0, 15] \setminus \{2, 5\}\} \longrightarrow 4 \quad (5.1)$$

As station  $B$  and  $C$  are in the communication range of station  $A$ , they can update their {Register slots} set by overhearing the ongoing transmission frame. As station  $C$  is in IDLE (sleep) mode, only station  $B$  updates the data. Because of bad wireless channel, station  $D$  can not decode the transmitted data frame successfully. Station  $D$  updates its database by overhearing the ACK frame of AP to station  $A$ . During the ACK frame transmission, a new data packet arrives at station  $C$ . Station  $C$  wakes

up, sensing the channel to understand that the channel is busy. As station  $C$  does not update its database during IDLE period, its knowledge of the neighbors is null.  $Register\ slots = \{\emptyset\}$ . Station  $C$  then draws a random backoff counter value, 8 in this example.

$$BK\_counter = RAND\{[0, 15] \setminus \{\emptyset\}\} \longrightarrow 8 \quad (5.2)$$

The transmission is model in time sequence as in Fig. 5.5 (b). As long as stations are able to collect some information of the others,  $\{Register\ slots\} \neq \emptyset$ , that information helps them prevent colliding transmissions better.

The proposed protocol ensures that connected stations will avoid collision with confidence. They gain channel access through a collaboration rather than a direct competition as in CSMA/CA. As depicted in Fig. 5.5 (b), it is clear that if we use purely randomized algorithm, we have to accept a certain amount of collision. If there is no prior-information at hand, randomized algorithm is the best strategy. If, however, stations are willing to release their future intentions, others can take a random value from a smaller set to prevent certain collision.

$iLAC$  attacks a hard, long standing problem with a simple solution which is easy to implement. It enables an efficient collaboration among connected stations, taking much of the randomness out of the decision-making process. Because it offers a systematic approach to setting proper value of the backoff counter,  $iLAC$  can prevent the conflict of using shared channel resources via a shared decision which in turn leads to a breakthrough in the individual as well as the network performance.

### 5.3 Analysis

One of the frequently cited models for analytical work is the Markov chain model in [4]. In this paper, the Markov chain approach is also used, as depicted in Fig. 5.6,

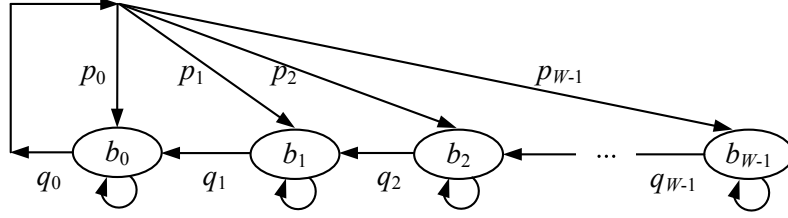

Figure 5.6: Markov model

to analyse the performance of the system. Those Markov stages and transition probabilities are encoded with the following symbols in Table 5.1.

Parameters	Explanation
$b_k$	Backoff state
$p_k$	probability of setting the backoff counter to $k$
$q_k$	transition probability

For simplicity, we take a fully connected, saturated network, an ideal channel and a large enough  $W$ . The following equation indicates the relation between  $b_0$  and the other states:

$$b_{W-k} = \frac{\sum_{l=1}^k p_{W-l}}{q_{W-k}} \frac{q_0}{\sum_{l=0}^{W-1} p_l} b_0 \quad (5.3)$$

Under the normalized condition:

$$\sum_{k=0}^{W-1} b_k = 1 \quad (5.4)$$

we get:

$$b_0 = \frac{1}{1 + \frac{q_0}{\sum_{l=0}^{W-1} p_l} \left( \sum_{k=1}^{W-1} \frac{\sum_{l=1}^k p_{W-l}}{q_{W-k}} \right)} \quad (5.5)$$

Transition probabilities are completely defined by:

$$\left\{ \begin{array}{l} q_k = \sum_{\substack{i_1=1 \\ i_1 \neq k}}^{W-1} \cdots \sum_{\substack{i_l=1 \\ i_l \neq i_1, \dots, i_{l-1} \\ i_l \neq k}}^{W-1} b_{i_1} \cdots b_{i_l} \\ p_k = \sum_{\substack{i_1=1 \\ i_1 \neq k}}^{W-1} \cdots \sum_{\substack{i_l=1 \\ i_l \neq i_1, \dots, i_{l-1} \\ i_l \neq k}}^{W-1} \frac{b_{i_1} \cdots b_{i_l}}{W - (N - 1)} \\ l = N - 1, N < W \end{array} \right. \quad (5.6)$$

The fundamental differences between DCF and *i*LAC are in the expression of  $p_k$  and  $q_k$ . In DCF  $p_k = \frac{1}{W}$  as in [4]. This is simply a uniform discrete distribution random value taken from  $[0, W-1]$  set. In contrast, in *i*LAC  $p_k$  is a real time, non-uniform, discrete distribution taken from subset of  $[0, W-1]$ ,  $\Omega = [0, W-1] \setminus \{\text{Register slots}\}$ . The  $\{\text{Register slots}\}$  is a set of collected knowledge of others' future intentions to access channel. With this solution, a station can actually prevent certain collisions with its local connected peers in the future transmission. The station only takes chance for available slots.  $q_k$  in *i*LAC will be the transmission probability when channel is free under the constraint that no future collision with local peers will occur. Therefore  $p_k$  and  $q_k$  are related to each other.

Under the above conditions, there is no collision among stations. A close observation of (5.6) shows that  $q_k = (W - (N - 1)) p_k$ . These relations can greatly reduce the complexity in solving the above equations.

Solving (5.6) gives us the complete distribution of the Markov chain. The activity in a time slot is given by the following equation:

$$\left\{ \begin{array}{l} P_S = N \times b_0 \times \sum_{i_1=1}^{W-1} \cdots \sum_{\substack{i_l=1 \\ i_l \neq i_1, \dots, i_{l-1}}}^{W-1} b_{i_1} \cdots b_{i_l} \\ P_I = \sum_{i_1=1}^{W-1} \cdots \sum_{\substack{i_{l+1}=1 \\ i_{l+1} \neq i_1, \dots, i_l}}^{W-1} b_{i_1} \cdots b_{i_l} \\ l = N - 1 \end{array} \right. \quad (5.7)$$

$P_S$  is the probability of a successful transmission of a frame in the network and  $P_I$  is the probability that a given time slot is idle. The normalized network throughput is:

$$S = \frac{P_S T_{Data}}{P_S T_S + P_I \sigma} \quad (5.8)$$

Delay expression:

$$\bar{D} = \sum_{i=0}^{W-1} \left( p_i \sum_{k=0}^i \frac{\bar{T}}{q_k} \right) \quad (5.9)$$

$$\bar{T} = P_S \times T_s + P_I \times \sigma \quad (5.10)$$

As  $W$  and  $N$  become large, the above equations become quite complex and cumbersome to evaluate. A simple example is provided to highlight the correctness of this solution.

### 5.3.1 Simple example: $N = 2$ and $W = 3$

According to Eq. 5.5,  $b_0$  becomes:

$$b_0 = \frac{1}{1 + \frac{q_0}{p_0 + p_1 + p_2} \left( \frac{p_2}{q_2} + \frac{p_1 + p_2}{q_1} \right)} \quad (5.11)$$

and the equations will become:

$$\begin{cases} p_1 = \frac{b_2}{2} = \frac{1}{2} \frac{p_2}{q_2} A \\ p_2 = \frac{b_1}{2} = \frac{1}{2} \frac{p_1 + p_2}{q_1} A \end{cases} \quad (5.12)$$

with the following relations:

$$\begin{cases} p_0 = p_1 + p_2 \\ q_0 = 2p_0 \\ q_1 = 2p_1 \\ q_2 = 2p_2 \end{cases} \quad (5.13)$$

and

$$\begin{cases} P_S = 2 b_0 (b_1 + b_2) \\ P_I = 2 b_1 b_2 \end{cases} \quad (5.14)$$

Delay expression:

$$\left\{ \begin{array}{l} \bar{D} = p_0 \frac{\bar{T}}{q_0} + p_1 \left( \frac{\bar{T}}{q_1} + \frac{\bar{T}}{q_0} \right) + p_2 \left( \frac{\bar{T}}{q_2} + \frac{\bar{T}}{q_1} + \frac{\bar{T}}{q_0} \right) \\ \bar{T} = P_s \times T_S + P_I \times \sigma \end{array} \right. \quad (5.15)$$

The delay presented here is only valid for an error free channel. In an erroneous wireless channel, the average delay will depend mainly on the retransmission strategy of the station. We do not go further than this point in our analysis. To validate those estimations, we use simulation parameters as in Table 5.3.

Table 5.2: Comparison

	Throughput [Mbps]	Delay [s]
Simulation	48.735292	0.0053789
Analysis	48.735412	0.0053746

### 5.3.2 Small network examples

Larger  $W$  and  $N$  will significantly increase the complexity of the analytical solution. As a result, the equations will be quite cumbersome to solve numerically. As a proof of the correctness of the analytical model, Fig. 5.7 compares the numerical analysis solution and the simulation under a limited setting as in Table 5.3. Other parameters are the same as in Table 5.4. The analytical solution shows the power of Markov chain analytical tool as it can predict the excellent performance of *i*LAC protocol.

## 5.4 Simulation

In order to quantitatively evaluate the merits of *i*LAC, simulations of wireless networks are carried out under various settings as in Table 5.4.



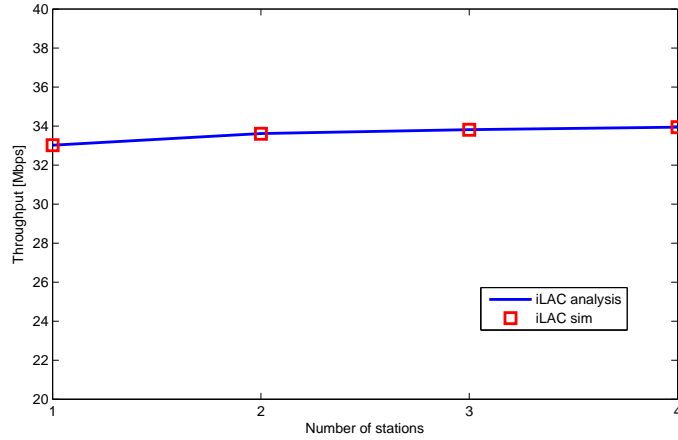

Figure 5.7: Analysis vs Simulation Comparison

Table 5.3: Simulation Parameters

Sim. Parameters	Value
$N$	1-4
Basic rate [Mbps]	6
Data rate [Mbps]	54
$W$	5
Frame Size [Bytes]	8*256
Frag. Size[Bytes]	256
BER	0

Our prime interest here is to study the impact of the proposed scheme on the performance of the network in the long term. As Aggregation with Fragment Retransmission (AFR) scheme [8] is the closest algorithm to our proposal, it is sensible to compare extensively its performance with *iLAC*. AFR scheme is an extension of DCF basic scheme. In the AFR scheme, data packets are broken into fixed and small fragments which are aggregated into and transmitted in a single large frame. If errors occur during the transmission, instead of the whole frame, only the corrupted fragments are retransmitted. In AFR, the process of channel access and frame transmission is identical to DCF basic scheme.

The same simulation strategy as in [8] is adopted. The simulator is developed in Matlab. Several conclusions can be drawn from simulation results. Firstly, the

Table 5.4: Simulation Parameters

Sim. Parameters	Value
$N$	1-15
Basic rate [Mbps]	6, 54, 300
Data rate [Mbps]	54, 300, 600
SIFS [ $\mu s$ ]	16
$\sigma$ [ $\mu s$ ]	9
DIFS [ $\mu s$ ]	34
$T_{hdr}^{phy}$ [ $\mu s$ ]	20
$CW_{min}$	16
$CW_{max}$	1024
Frame Size [Bytes]	64*256 (Fig. 5.7-5.12) 256-262144 (Fig. 5.13) 2048 (Fig. 5.14) 8192 (Fig. 5.15)
Frag. Size[Bytes]	256 (Fig. 5.7-5.12) 64-8192 (Fig. 5.14-5.15)
BER	0, $10^{-6}$ , $10^{-4}$

performance of *i*LAC and AFR is compared under an ideal channel condition. The actual throughput of AFR is much lower than the maximum throughput that PHY layer offers. As clearly observed in Fig. 5.8, only around 60% of channel has been utilized when the network size becomes 15. As the network size increases, the contention overhead becomes much more prominent and drives down the total network throughput, which shows an unparalleled development in the two lower layers. The MAC layer lags far behind the advancement of PHY layer and therefore becomes a bottleneck of a very high speed WLAN network.

It is noted that when the number of stations increases, the network throughput remains stable in the case of *i*LAC while decreasing considerably in the case of AFR. With *i*LAC, the larger number of stations hardly causes collisions, but actually reduces free slots. Therefore, when the network size increases, the throughput approaches a hard limit set by the transmission header.

We believe that the joint decision approach is a fair and efficient method to allocate the scarce and finite wireless channel resources. The role of MAC layer is to regulate

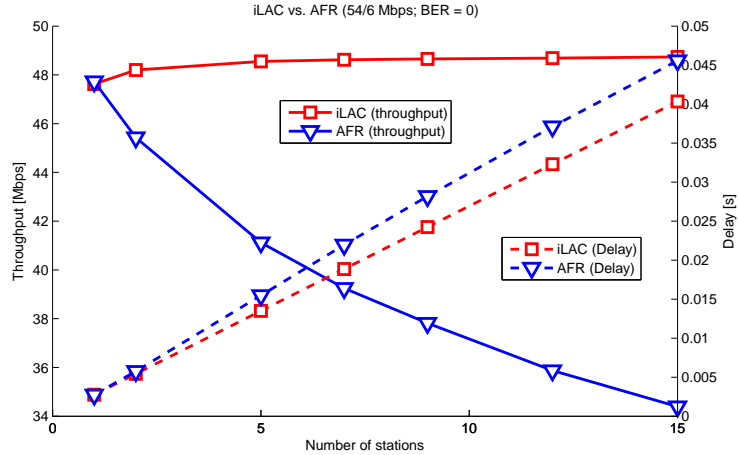

Figure 5.8: Throughput/Delay Comparison

and control the transmission process smoothly. Under the conventional 802.11 DCF, the decision for setting a backoff value is realized through randomized algorithm. Because of that, it is natural for DCF to guarantee long term fairness among peers. In *iLAC*, we reason that the nature of wireless channel makes it extremely easy to solve the colliding transmission problem. It would also be beneficial to ensure that all neighbours get an equal channel access even though *iLAC* changes the way the backoff counter is set.

In this paper, we use the max-min fairness index [5] to examine the long-term fairness of *iLAC*. The results taken from one simulation run indicate that *iLAC* achieves the same performance as AFR as in Fig. 5.9.

Fig. 5.10- 5.12 compare the two protocols under different transmission speeds. Overall, *iLAC* outperforms AFR in all settings. With respect to the frame size, AFR and *iLAC* seem to operate almost equally well at very small frame sizes in Fig. 5.13, but their performances differs considerably at larger frame sizes. As the frame size increases, the effect of excessive collision destroys the benefit of AFR. In collision, the whole frame will be corrupted. Therefore, it is particularly risky to transmit big frame with AFR. On the other hand, thanks to its intrinsic mechanism, *iLAC* effectively eliminates collisions on real time basis, not just by simple blind guessing

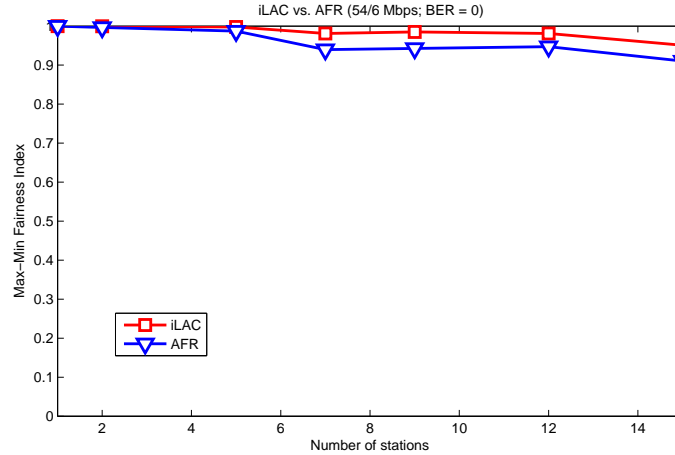

Figure 5.9: Fairness Index

as in AFR. Therefore, the only factor that lowers the performance of *iLAC* is the erroneous wireless channel itself.

Logically, the throughput of an ideal channel will increase as the relative duration for a payload transmission increases. However, in real wireless channels, simply increasing the payload size does not work. This reasoning is clearly shown in the DCF curve. Big payload is error-prone. A few error bits could destroy all the effort of the whole frame transmission. AFR curve shows a big improvement in terms of system throughput because erroneous bits can only corrupt a few fragments while the rest of the frame can still be decoded successfully. This is the most recognizable merit of incorporating frame aggregation into 802.11n standard.

How does *iLAC* compare to other protocols when the fragment size changes? The comparison given in Fig. 5.14- 5.15 depicts the relation between the fragment size and the network throughput. When the channel is good, the fragment size has little effect on the network throughput. However, when the channel is bad, increasing fragment size noticeably reduces the system performance. *iLAC* still performs better than AFR in this case.

When the number of stations exceeds the minimum contention windows ( $CW_{min}$ ), some stations will double their contention windows ( $W = 2CW_{min}$ ) when they find

that all the first  $CW_{min}$  slots are occupied. The backoff counter value will be drawn from a larger set,  $rand( [0, W-1] \setminus \{\text{Register slots}\} )$ . The result is shown in Fig. 5.16. As the number of stations increases, the performance of AFR degrades accordingly while *i*LAC maintains a fairly stable throughput.

Let's consider the performance of *i*LAC under an unsaturated condition. All stations have a buffer length = 10 and the same arrival rate ( $\lambda$ ). After successfully sending a frame, if there is no data packet in queue, the station will enter the post backoff procedure. In *i*LAC, the post backoff value will be set with *Next BK* value. During the backoff countdown process, the station is still in an active stage and therefore can update its database by overhearing ongoing transmission frames. However, when the backoff expires and the queue is still empty, the station will go into the sleep mode to save energy. In the sleep mode, the station can not update its database. It will be active again when a new packet arrives. The performance of *i*LAC under an unsaturated condition is given in Fig. 5.17. When the arrival rate is small, *i*LAC and AFR offer almost the same performance because stations transmit frames without or with a very little collision. However, when the arrival rate is high enough, *i*LAC is apparently superior to AFR.

Beside the imperfect wireless channel and colliding transmissions, the hidden terminal significantly degrades the performance of wireless network. Previous results in this paper indicate that in a connected network, *i*LAC can effectively prevent colliding transmissions by overhearing data frames or ACK frames. This section investigates the performance of *i*LAC in the existence of a hidden station. A small group of stations ( $N=5$ ) transmit to an Access Point and a hidden station also connects to that Access Point. All stations are in an unsaturated condition. The result in Fig. 5.18 shows that *i*LAC yields a higher group's throughput than that of AFR. As stations exchange information, the hidden station knows how to defer its transmission to avoid a conflict. Due to the small arrival rate, some stations are in idle state when new

data packets arrive. The hidden station only has partial knowledge of the group, therefore, collision still occurs. In an extreme case, the hidden station transmits data frames following AFR scheme while a group of connected stations use *i*LAC protocol for data transmission. The hidden station has a small arrival rate while the stations in group are in a saturated condition. Although the hidden station overhears ACK frame, it does not utilize the *Next BK* information. The result in Fig. 5.19 depicts that the hidden station causes a significant degradation of the network throughput. However, *i*LAC protocol still offers superior performance to AFR protocol.

Simulation outputs reveal that *i*LAC has a robust and consistent advantage over the strongest competitor AFR. Therefore, *i*LAC is able to supersede AFR for the high speed wireless transmission MAC protocol.

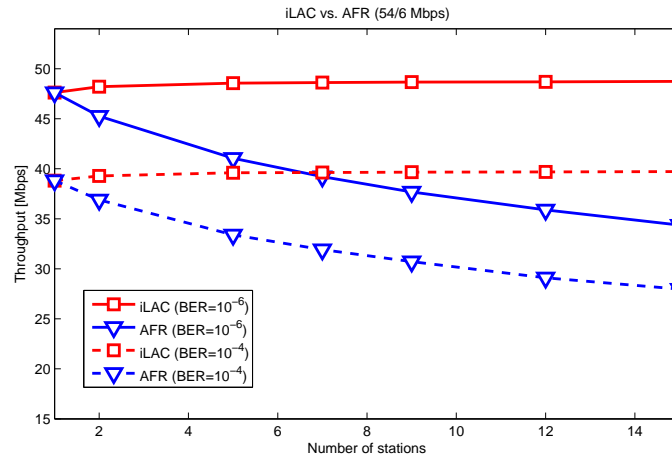

Figure 5.10: Throughput Comparison

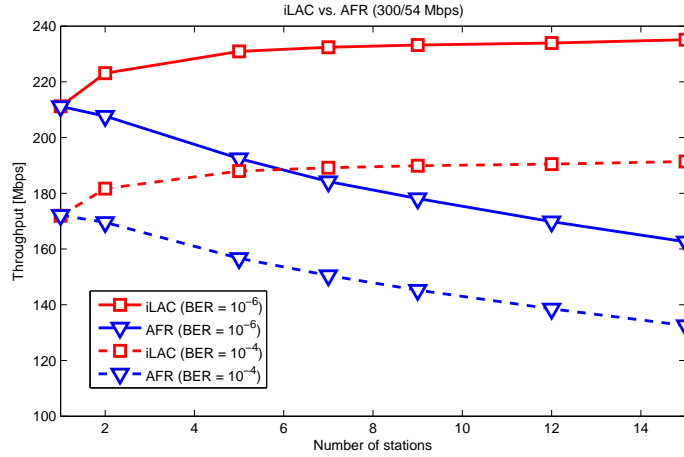

Figure 5.11: Throughput Comparison

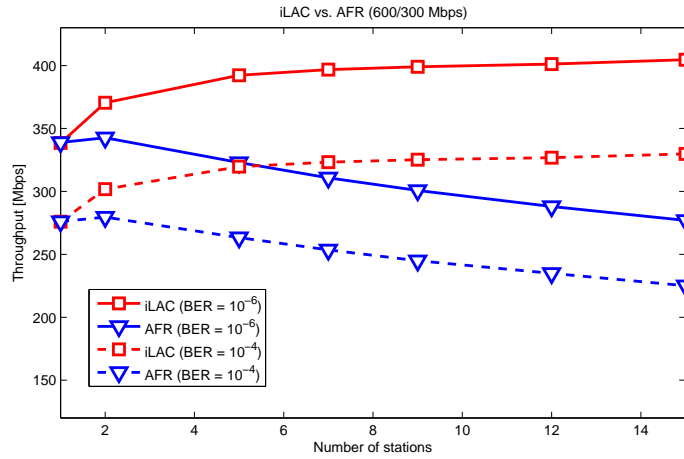

Figure 5.12: Throughput Comparison

## 5.5 Energy consumption

Generally speaking, the energy consumption of WLAN in a saturated condition is demonstrated by the following equation:

$$\begin{aligned}
 J = & J_{tx ACK}^s + J_{rx ACK}^s + \\
 & J_{tx ACK}^c + J_{rx ACK}^c + J_{rx}^c + J_{tx}^c + J_{\sigma}
 \end{aligned} \tag{5.16}$$

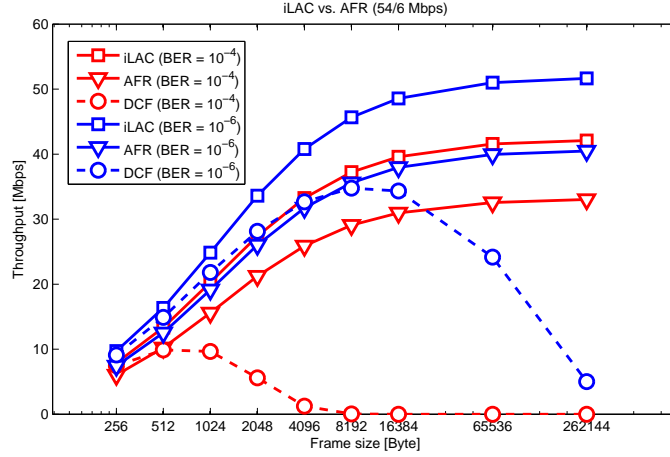

Figure 5.13: Throughput Comparison (N=10, Frag. size = 256 Bytes)

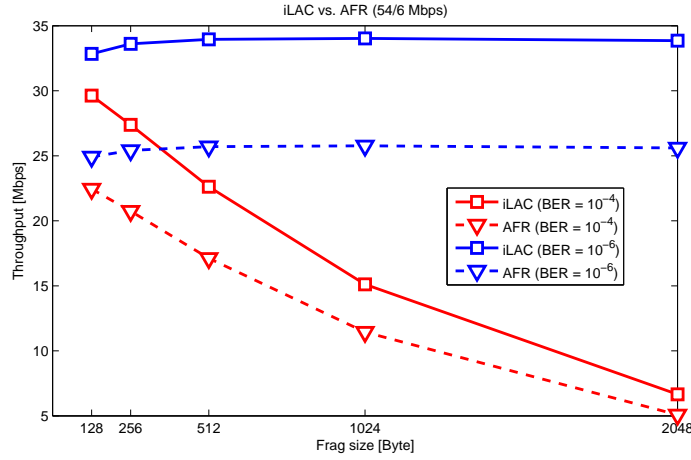

Figure 5.14: Throughput Comparison (N=10, Frame size = 2048 Bytes)

$J_{tx ACK/\overline{ACK}}^s$  are the energy consumption of station to transmit a data frame without collision. Due to the channel corruption, Access Point (AP) may not receive that frame successfully. Therefore, AP does not respond with ACK frame. This event is indicated by the over line ( $\overline{ACK}$ ).  $J_{rx ACK/\overline{ACK}}^s$  are the energy consumption of a station to overhear the ongoing transmission of another terminal.  $J_{tx/rx}^c$  are the energy consumption in colliding transmission.  $J_\sigma$  is energy consumption of a station to overhear while counting down the backoff counter. In basic mode, the followings



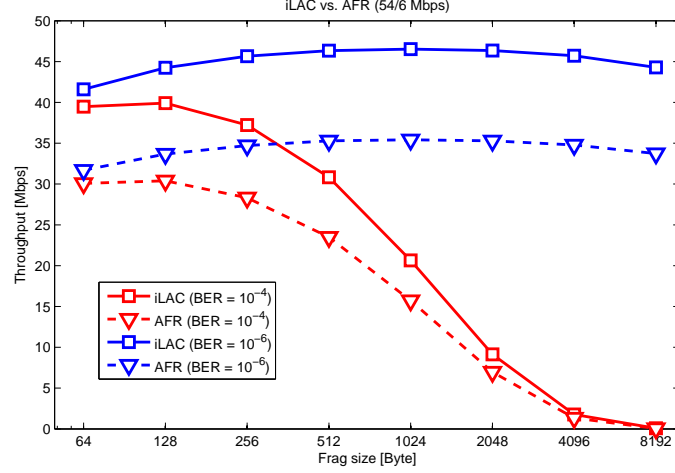

Figure 5.15: Throughput Comparison (N=10, Frame size = 8192 Bytes)

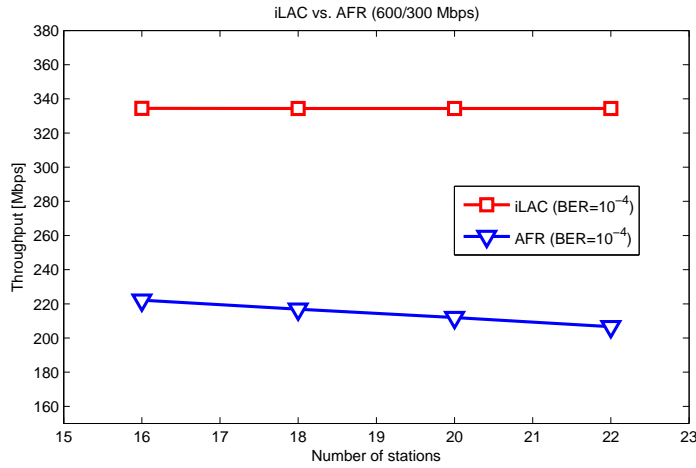

Figure 5.16: Throughput Comparison

are the detailed energy consumption for each events:

$$J_{rx ACK}^s = \rho_{rx} T_F + \rho_{rx} T_{ACK} + \rho_{\sigma} (SIFS + DIFS)$$

$$J_{rx \overline{ACK}}^s = \rho_{rx} T_F + \rho_{\sigma} (SIFS + T_{ACK} + DIFS)$$

$$J_{tx ACK}^s = \rho_{tx} T_F + \rho_{rx} T_{ACK} + \rho_{\sigma} (SIFS + DIFS)$$

$$J_{tx \overline{ACK}}^s = \rho_{tx} T_F + \rho_{\sigma} (SIFS + T_{ACK} + DIFS)$$

$$J_{rx}^c = \rho_{rx} T_F + \rho_{\sigma} (SIFS + T_{ACK} + DIFS)$$

$$J_{tx}^c = \rho_{tx} T_F + \rho_{\sigma} (SIFS + T_{ACK} + DIFS)$$

$$J_{\sigma} = \rho_{\sigma} \sigma \quad 112 \quad (5.17)$$

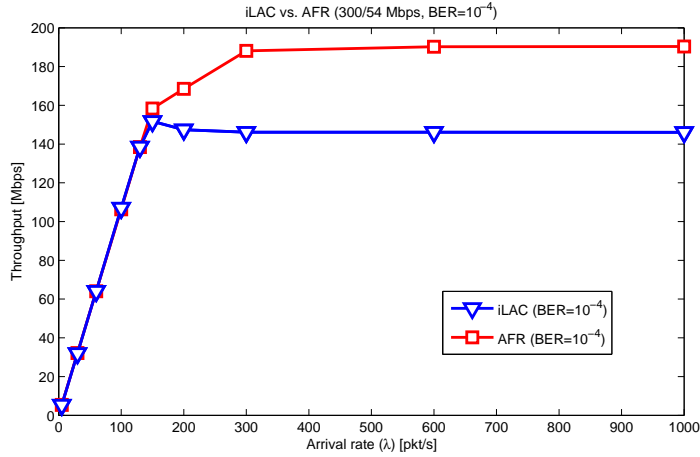

Figure 5.17: Throughput Comparison (N=10, Frame size = 64\*256 Bytes)

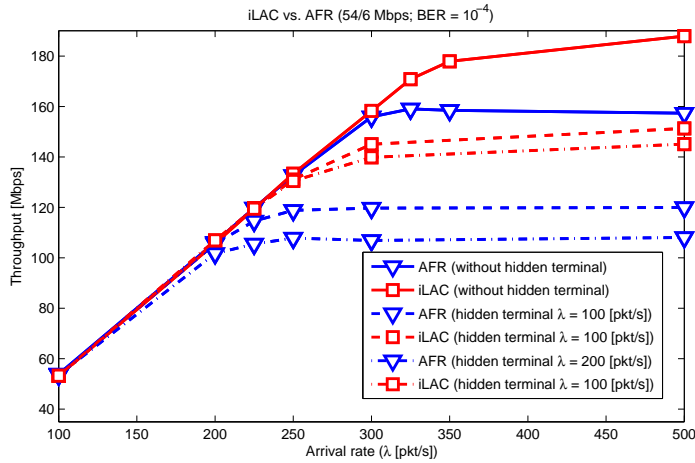

Figure 5.18: Throughput Comparison (Frame size = 64\*256 Bytes)

Dissecting equation (5.16), we observe that only the first term is the true portion energy consumption to transmit data. Energy consumption of the first two terms is necessary for successful transmitting and receiving transmissions. The other terms are wasteful energy. We will demonstrate that *i*LAC protocol changes this pattern of energy consumption by effectively reducing colliding transmissions.

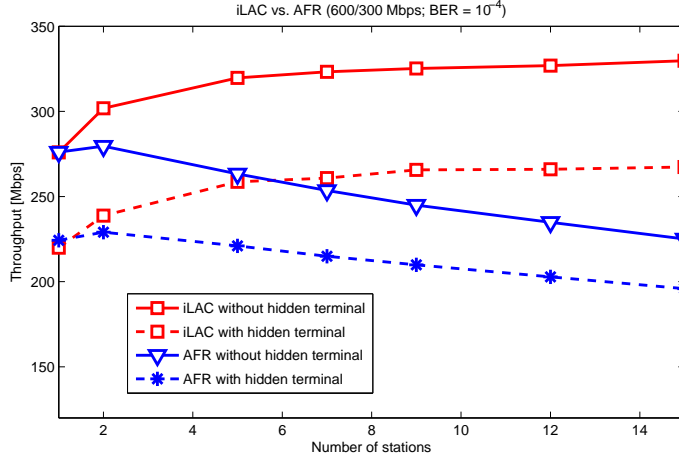

Figure 5.19: Throughput Comparison (Frame size = 64\*256 Bytes, Hidden terminal arrival rate ( $\lambda$ )=10<sup>2</sup> [pkt/s])

The results in (5.7) help us to calculate the energy consumption for a successful transmission of a bit (Joule/bit):

$$\overline{J}_b = \frac{P_S J_{tx}^s ACK + (N - 1) P_S J_{rx}^s ACK + N P_I J_\sigma}{P_S \times pktSize} \quad (5.18)$$

Fig. 5.20 compares the results of the numerical analysis solution and simulation in limited cases ( $W = 5$ ). Simulation is done with WLAN card B (2Mbps) in table 5.5. The upper line illustrates the network throughput and the lower line depicts energy consumption in Joule/bit. The analytical solution shows a similar result performance of *iLAC* protocol with great accuracy.

In this section the protocol is evaluated under the 802.11b environment, although *iLAC* can be used in any other 802.11 setting. The power consumptions of WLAN cards have been reported in [12]-[13]. As our main objective is to evaluate the performance of *iLAC* protocol, we only need practical measurements of some WLAN cards' power consumptions in IDLE ( $\rho_\sigma$ ), Transmitting ( $\rho_{tx}$ ) and Receiving ( $\rho_{rx}$ ) states without going into real products detail. To ensure a pure technical evaluation process, we

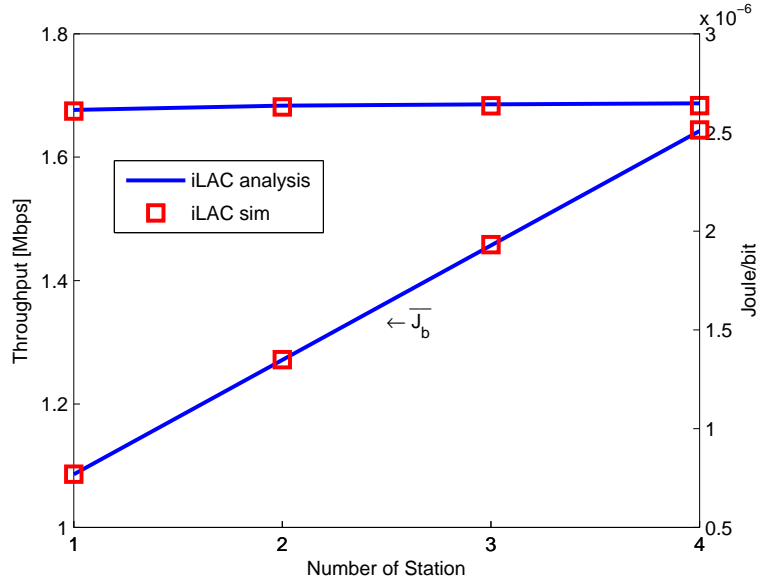

Figure 5.20: Analysis vs. Simulation Comparison for Throughput

will refer to some WLAN cards in our paper by artificial names as in Table 5.5 for simulations purpose.

Table 5.5: Power consumption of some 802.11b cards

802.11b WLAN cards	$\rho_{tx}$ [W]	$\rho_{rx}$ [W]	$\rho_{\sigma}$ [W]
WLAN card A (1Mbps)	1.65	1.4	1.4
WLAN card B (2Mbps)	1.321	0.982	0.869
WLAN card C (11Mbps)	1.4	0.9	0.9
WLAN card D (1Mbps)	2.2	1.35	1.35

This part provides a detailed analysis of the power consumption of *iLAC* under different settings and different types of Wireless LAN cards. Results are given in Fig. 5.21-5.30.

We first study the average energy allocated to a slot. Results are illustrated in Fig. 5.21-5.22. *iLAC* has allocated significantly higher amount of energy per slot compared to DCF across all WLAN cards under consideration. With the same transmission speed, the difference between WLAN card A (1Mbps) and WLAN card D (1Mbps) is negligible.

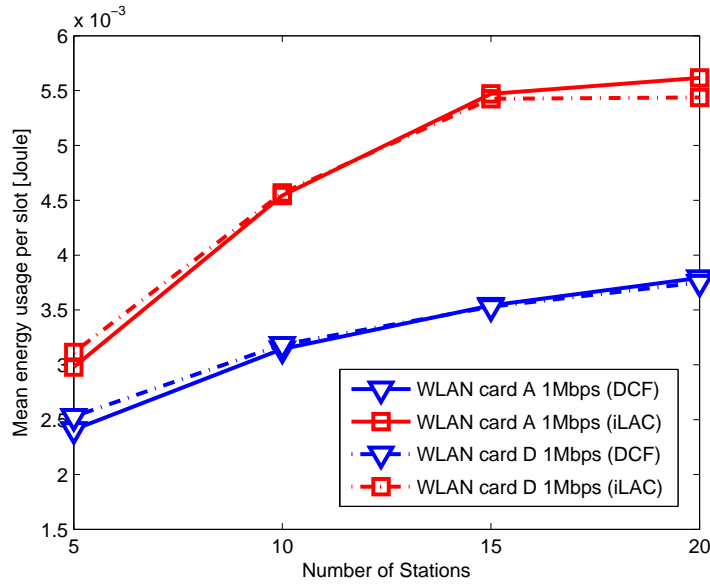

Figure 5.21: Energy per slot

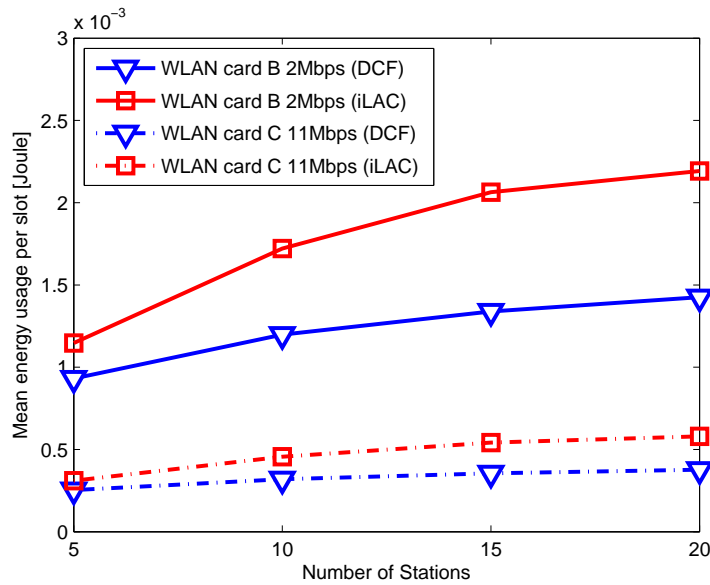

Figure 5.22: Energy per slot

The effective energy is defined as the energy consumption for a successful transmission over the total energy consumption of a station. This measure reflects the efficiency of MAC protocol for transmissions. Simulation results in Fig. 5.23-5.24 indicate that the effective energy decreases as the network size increases. The results

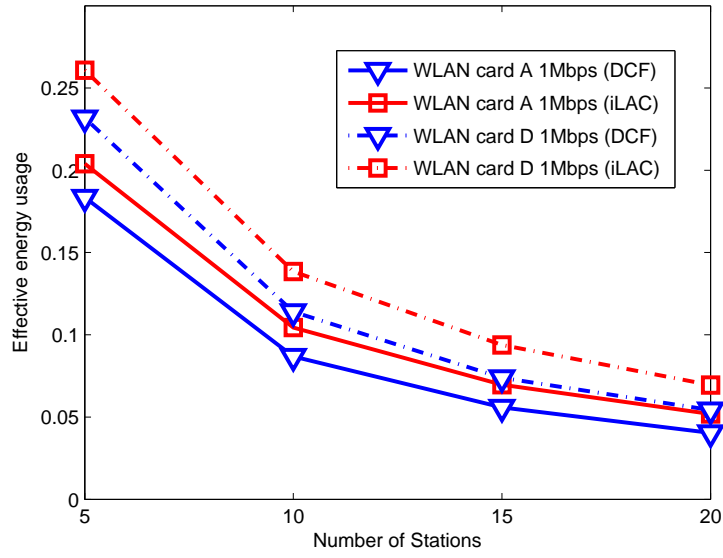

Figure 5.23: Effective energy

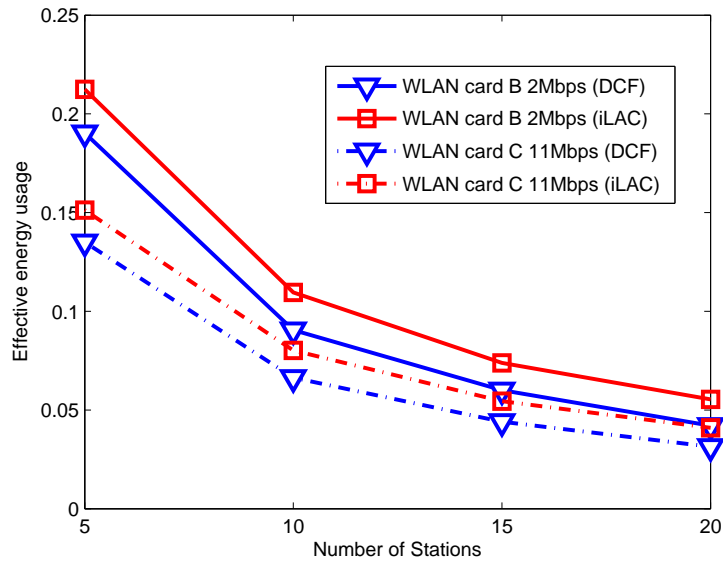

Figure 5.24: Effective energy

are logical as the station has to use much of its energy for other activities such as over-hearing or colliding transmission. It is observed that *iLAC* offers a better energy usage over DCF.

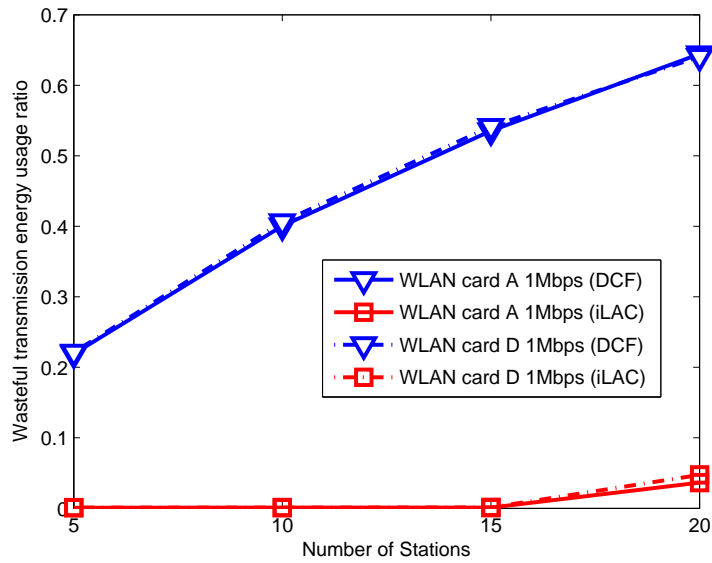

Figure 5.25: Wasteful energy

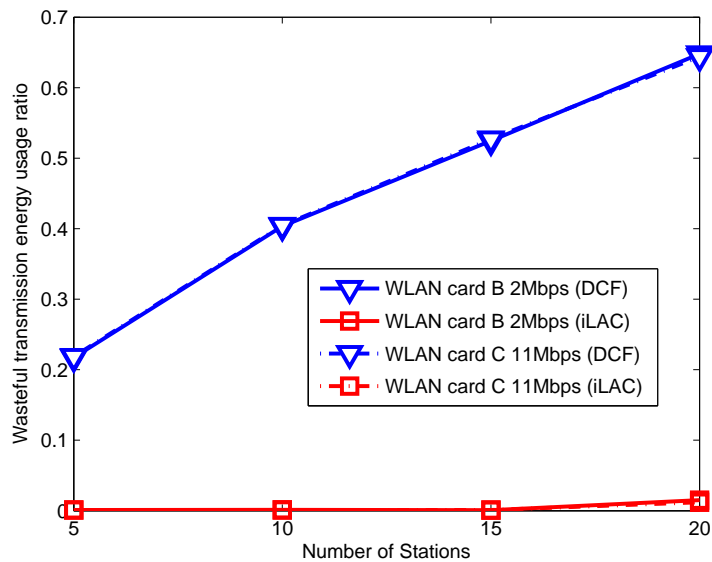

Figure 5.26: Wasteful energy

The role of MAC layer is to regulate and control the transmission process smoothly. Under the conventional 802.11 DCF, the decision for setting backoff value is realized through randomized algorithm. It is expected that collision will occur at a higher rate as the network size increases. Excessive collision will be the source of a quick

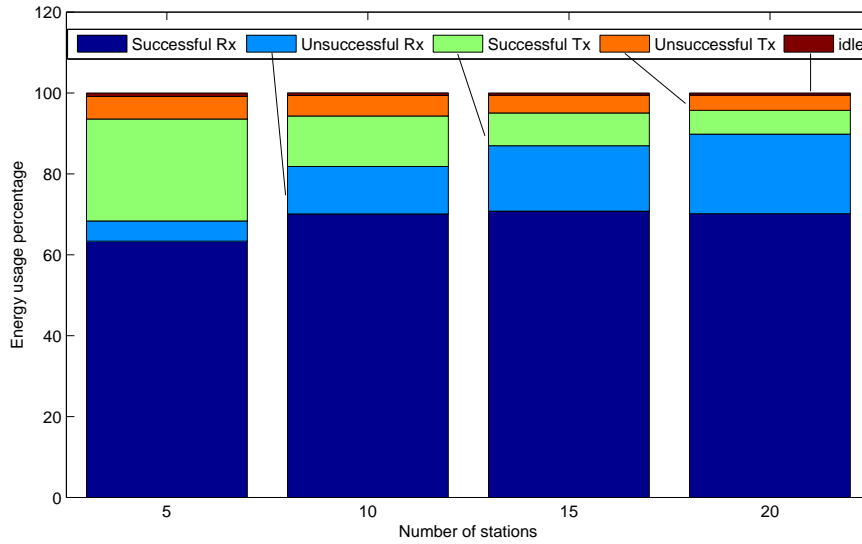

Figure 5.27: WLAN card D DCF Energy Structure

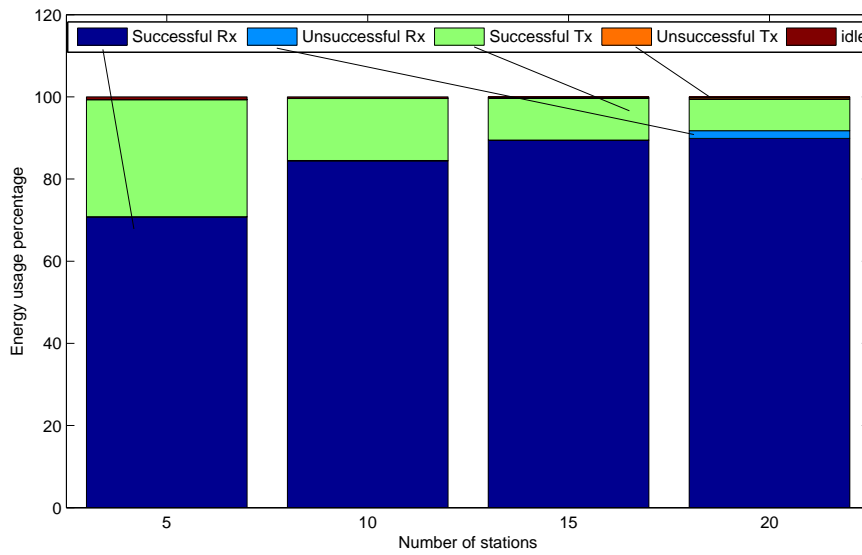

Figure 5.28: WLAN card D *iLAC* Energy Structure

battery depletion. We introduce a wasteful energy measure, which is defined as energy consumption for no ACK responses - colliding transmissions or transmissions are corrupted by a wireless channel - over the total energy consumption. Results are given in Fig. 5.25-5.26. When a data frame or a ACK frame is corrupted, stations



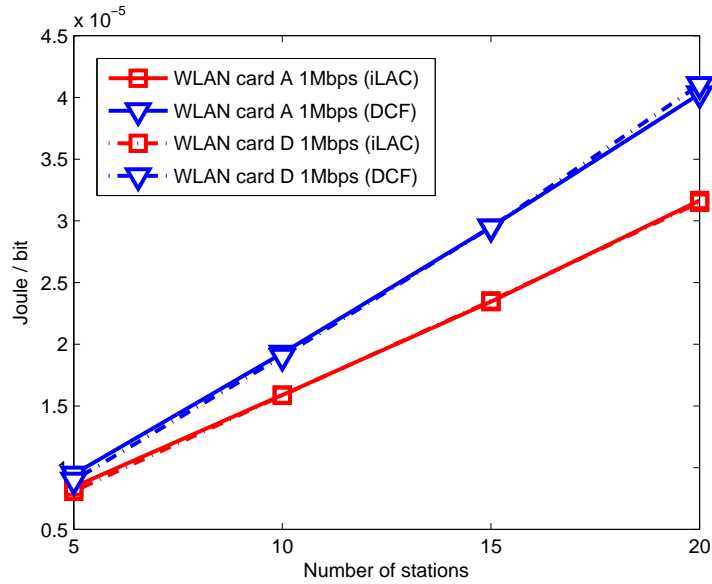

Figure 5.29: Energy per bit

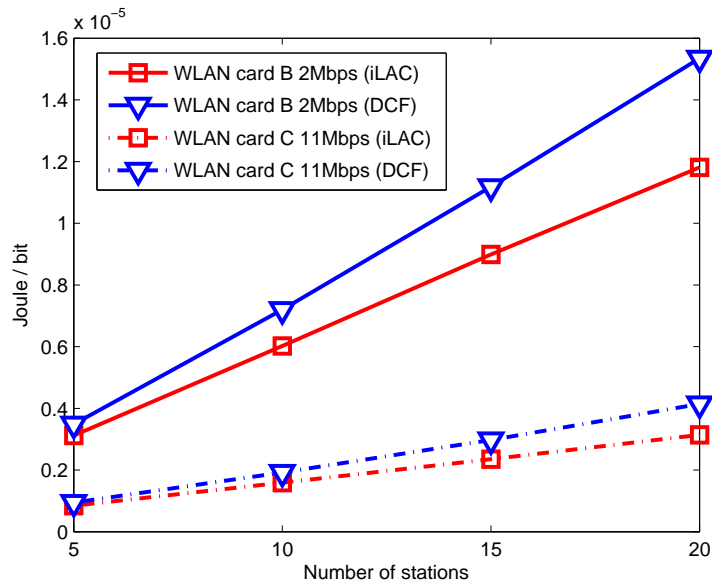

Figure 5.30: Energy per bit

cannot gather enough information of the neighbors. Therefore collisions still happen in *iLAC*. The results show that *iLAC* prevents collision better than DCF.

How does *iLAC* compare to DCF in terms of the whole energy consumption structure? The comparison is given in Fig. 5.27-5.28. The collaboration strategy that

we introduced in *iLAC* has completely changed the structure of energy consumption of a station. Although results are only given to WLAN card D, the performance of other cards are somewhat similar. The wasteful energy consumption for unsuccessful transmissions and receptions are effectively eliminated. In *iLAC*, the predominant energy consumption is for reception frames. The less dominant portion of energy consumption is dedicated to successful transmissions. Unsuccessful transmissions, receptions and idle only account for a negligible portion in this structure. Most of the wasteful energy consumption in DCF has been translated to useful parts.

Finally, we examine the energy per bit of a successful transmission. The comparisons are presented in Fig. 5.29-5.30. The results presented here explain why *iLAC* has higher energy per slot. The main reason is that most of the energy consumption in a slot is for successful transmission. Therefore, with the same energy consumption, *iLAC* can deliver higher information content than DCF. The improvement in energy per bit is larger when the network size increases. A direct result of *iLAC* on energy per bit is that it can improve battery life in mobile devices.

Simulation outputs demonstrate that *iLAC* offer a robust and consistent advantage over DCF as significant improvement in all 802.11b WLAN cards has been recognized.

## 5.6 Conclusion

This chapter introduces a new MAC protocol, called *iLAC*, which attempts to solve the problem of colliding transmission in WLAN. In principle, *iLAC* utilizes the collaborative decision of setting a backoff counter state of a wireless station to prevent future colliding transmissions among neighbouring stations. The mathematical analysis proves the validity of *iLAC* protocol in a fully connected network. As *iLAC*

efficiently allocates the scarce wireless channel resources to each user through a joint decision procedure, it is highly appropriate for very high speed WLAN.

We also focus on the power consumption of *i*LAC MAC protocol. The study shows that *i*LAC is an effective protocol, especially to reduce energy consumption. These advantages are critical for small personal handheld devices. Therefore *i*LAC can be a "green" MAC protocol solution for condense, high-demand hot-spots Wi-Fi networks.

Another distinguishing feature of *i*LAC is that it makes a major shift in the MAC protocol design from simple collision avoidance to early collision prevention through collaboration. Finally, *i*LAC is simple in implementation which requires no additional support from the PHY layer and the existing system can be upgraded through firmware update.

This chapter verifies the capability of *i*LAC for very high speed WLAN. However, the application of *i*LAC is not limited to cases examined in this paper. We are working on other scenarios to bring this protocol to a wider applications such as multi-hop wireless transmission networks.

# Bibliography

- [1] IEEE Std 802.11. Part 11: wireless LAN medium access control (MAC) and physical layer (PHY) specifications, 2007.
- [2] IEEE Std 802.11n. Part 11: Wireless LAN Medium Access Control (MAC) and Physical Layer (PHY) Specifications, March 2009.
- [3] G. R. Hiertz, D. Denteneer, L. Stibor, Y. Zang, X. P. Costa, B. Walke, "The IEEE 802.11 universe," IEEE Communications Magazine, vol. 48, no. 1, pp.62 - 70, Jan. 2010.
- [4] G. Bianchi, "Performance Analysis of the IEEE 802.11 Distributed Coordination Function," IEEE Journal on Selected Areas in Communications, vol. 18, no. 3, pp.535 - 547, Mar. 2000.
- [5] D. P. Bertsekas, R. Gallager, Data Networks, Prentice Hall 1992.
- [6] Y. Xiao, "IEEE 802.11 performance enhancement via concatenation and piggy-back mechanisms," IEEE Transactions on Wireless Communications, vol. 4, no. 5, pp.2182 - 2192, Sept. 2005.
- [7] D. C. Hieu, S. Shimamoto, "Continuous Contention-Assisted Transmission MAC Protocol for Wireless Ad-Hoc Network," GLOBECOM 2009, Nov. 2009.

- [8] T. Li Q. Ni, D. Malone, D. Leith, Y. Xiao, T. Turletti, "Aggregation With Fragment Retransmission for Very High-Speed WLANs," *IEEE/ACM Transactions on Networking*, vol. 17, no. 2, pp. 591 - 604, Apr. 2009.
- [9] Y. Lin, W.S. Wong, "Frame Aggregation and Optimal Frame Size Adaptation for IEEE 802.11n WLANs," *GLOBECOM 2006*, Nov. 2006
- [10] B. Ginzburg, A. Kesselman, "Performance analysis of A-MPDU and A-MSDU aggregation in IEEE 802.11n," *Sarnoff Symposium*, Apr. 2007.
- [11] C. Y. Wang, H. Y. Wei, "IEEE 802.11n MAC enhancement and performance evaluation," *Springer Mobile Network Application*, vol. 14, no.6, pp.760-771, 2009.
- [12] L. M. Feeney, M. Nilsson, "Investigating the Energy Consumption of a Wireless Network Interface in an Ad Hoc Networking Environment", *IEEE Infocom 2001*
- [13] M.M. Carvalho, C. B. Margi , K. Obraczka , J. J. Garcia-Luna-Aceves, "Modeling Energy Consumption in Single-Hop IEEE 802.11 Ad Hoc Networks", *13<sup>th</sup> International Conference on Computer Communications and Networks (ICCCN)* 2004

# Chapter 6

## Conclusion

The increasing popularity of the mobile devices in recent years has drawn much attention to basic research on wireless communications technologies. One of the fundamental parts of wireless communication system is the Medium Access Protocol (MAC). We focus on the new MAC protocol designs for high speed data transmission for wireless local area networks in this dissertation. There are two new MAC protocols are proposed in chapter 3 and 5. A mathematical analysis solution for a previously proposed MAC prtotocol is presented in chapter 4.

### **Chapter 1 Introduction**

This chapter provides an overview of the current and near future wireless network. The serious challenge of wireless communications is to deliver huge amount of data for end users. It is expected that high quality video and big file transmissions will be the dominant traffic of mobile users.

To meet this requirement, new spectrum should be allocated and innovative technologies should be applied. The process of allocating new spectrum is quite slow and may never meet the increasing spectrum requirement of mobile community. Therefore much the short term solutions come from new technologies such as: better coding, MIMO, off-loading techniques,... The off-loading approach is the most viable tech-

nology. Most of the heavy traffic such as huge file downloading, video streaming,... should go through high speed wired networks and then only deliver to end user at the last stage by wireless technologies such as femtocell or WLAN. The simple, highly effective and world-wide deployed WLAN networks is the most suitable solution. Exploring such capability is the active research trend currently. Beside identifying the research topic, this chapter also introduces plan and structure of this dissertation.

## **Chapter 2 Multiple Access Techniques**

MAC protocol study is an old research topic which we can trace back to the very beginning of communication system. However, this field of study is among the most active research areas currently. New communication systems, new wireless applications demands suitable MAC protocols to maximize system performance. It is therefore impossible to have a comprehensive review of this research area.

In this chapter, we only review the relevant MAC protocols, which directly or indirectly influence the final outcome of our effort to design more suitable MAC protocols of high performance wireless networks. Many wireless MAC schemes have origin from ALOHA protocol. The development of wireless technology in the physical layer, and especially the demand of a wide range of applications yield a very diverse wireless MAC scheme family. We, therefore, try to follow the development of each branch to highlight the idea development, performance improvement and major academic achievements. During the course of studying the above mentioned protocols, we paid special attention to the analytical parts. The analytical solution plays a key role in MAC protocol research. It provides insight to the design, parameters setting. And analytical solution is also an important tool to investigate the behavior of wireless system as a whole. The most powerful tool for our MAC protocol performance analysis is Markov chain framework. Markov chain analysis has been successfully applied to investigate several MAC schemes. Our achievements based firmly on these analytical solutions.

### **Chapter 3 Continuous Contention-Assisted Transmission (CAT) MAC Protocol for Wireless Ad-Hoc Network**

The proposal is inspired by token passing scheme in wired-network. However, applying this scheme to wireless environment poses several serious challenges.

- Firstly, not every wireless station can receive token.
- Secondly, the error prone wireless environment may destroy the token unexpectedly.
- And finally, wireless network is a highly dynamic network, stations can join and leave the network without prior notification.

To address those difficulties, we proposed the Continuous contention-assisted transmission MAC protocol for the wireless ad-hoc network. Stations in close proximity should form into a group to coordinate transmissions. Ideally all station in group should be within transmission range in order for the token to be handled reliably. The right to transmit frame of a station on shared wireless channel is decided by previously successful receiving stations in a random fashion. Giving the channel access right to station has data to send will much reduce its random access effort. If the token is passed to station with no demand for channel access then this token is discard. Then a new phase of random access begins. With this proposal, transmissions are organized distributedly to reduce conflict among group. In low traffic network, the CAT protocol behaves as random access protocol. When traffic increase, transmissions of stations are quickly scheduled to eliminate unnecessary collisions. Direct result of this proposal is the increase of group throughput. The proposal is suitable for small networks which stations are closed enough to be efficiently organize into non-contending group.

The proposed protocol is analysed by mathematical analysis and numerical simulation. Using Markov chain analysis, the theoretical solution proved the superiority



of this proposal. Numerical simulation confirmed the feasibility of CAT protocol in various scenarios.

#### **Chapter 4 One-ACK Protocol**

One ACK protocol is a very promising candidate for high speed MAC protocol of WLANs. The protocol has been proposed with excellent result only by numerical simulation. This chapter demonstrated the mathematical analysis of One-ACK protocol to complete the proposal.

With the demand of large data transmission in high speed network, the major requirement to deliver such huge data is put into the MAC protocol design. Naturally, high speed communication requires big transmission packets. However large frames cannot reliably transmit through wireless channel. Wireless channel may corrupt the whole frame reception and consequently causes a costly retransmission. As the error in wireless channel is bursty in nature, it is best to fragment the big packet into smaller ones with optimum size. When error happens during the transmission, the MAC layer can localize the corrupted parts in the original frame. The MAC layer then decides to retransmit the only fragments that have been corrupted by channel. The idea reduces much of unnecessary retransmission of large frames. Furthermore, one-ACK organizes retransmission of corrupted fragments so as to reduce overhead.

The protocol had only been investigated by simulation by NS-2 previously. It is needed a concrete mathematical proof to complete the proposal. In this chapter, we presented an analytical solution. with erroneous wireless channels. Retransmission policy is also incorporated into the solution in order to assist the designers. The solution can precisely predict the performance of one-ACK protocol under various simulations setting of retransmission strategies.

#### **Chapter 5 Intelligent Local Avoided Collision (iLAC) MAC Protocol for Very High Speed Wireless Network**

The new MAC protocol design described in this chapter took a very different approach with conventional MAC protocol designs. Normally, the transmission process is a matter of transmitter and receiver alone. This chapter investigate the scenario that many stations involve in the transmission. Even the overhearing stations can actively participate in the scheduling process to avoid future conflict.

Generally, the scheduling job is mainly decided by a coordinator node. However in highly dynamic wireless network, installing another management layer is quite costly solution. Therefore distributed scheme to handle the coordination work is needed. In iLAC protocol, neighboring stations continuously exchange information of back-off stage counter settings via the header of every frames transmission. Because all stations can overhear this information, they adjust their backoff value accordingly to avoid future conflict with that transmitting station. Therefore collisions are eliminated efficiently among neighbors. Coordinating transmission by this scheme reduce wasteful energy significantly due to unproductive colliding transmissions.

Mathematical analysis using Markov chain shows excellent agreement with simulations. Using real power consumption measurement data, we show significant improvement in the power consumption structure of stations.

## **Chapter 6 Conclusion**

This chapter provides our conclusions on the achievements of this dissertation. We currently investigate other aspect of the proposed MAC protocols. Some of the promising topics are outlined as near future researches:

- How does hidden terminal affect system performance?
- The interaction of several groups?
- In real wireless environment, not all stations can overhear correctly the transmitting frames. How does the lack of global knowledge of network influence the collision level?

## Appendix: List of academic achievements

<p>Articles in refereed journals</p>	<ul style="list-style-type: none"> <li>○ D. C. Hieu, T. Nguonly, S. Shimamoto, Analysis of one-ACK fragmentation MAC protocol for 802.11n under saturated condition, Simulation Journal Vol.2, No.2, pp. 50-56, Jun. 2010, Japan.</li> <li>○ D. C. Hieu, A. Masuda, V. H. Rabarijaona, S. Shimamoto, Intelligent Local Avoided Collision (iLAC) MAC Protocol for Very High Speed Wireless Network, IEICE Trans. Commun., vol. E95-B, No. 2, pp. 392-400, Feb. 2012.</li> </ul>
<p>Presentations at International conferences</p>	<ul style="list-style-type: none"> <li>○ D. C. Hieu, S. Shimamoto, Continuous Contention-Assisted Transmission MAC protocol for Wireless Ad-Hoc Network, Golobecom 2009, pp. 1-6, Nov. 2009.</li> </ul>
<p>Presentations at domestic conferences</p>	<p>D. C. Hieu, S. Shimamoto, Saturated throughput analysis of CSMA/CA using fixed slot time scheme, Japan Simulation Conference 27th, Jul. 2008.</p> <p>D. C. Hieu, S. Shimamoto, Analysis of the 802.11 DCF in non-saturated condition using fixed slot time scheme, Japan Simulation Conference 28th, Jul. 2009.</p>